

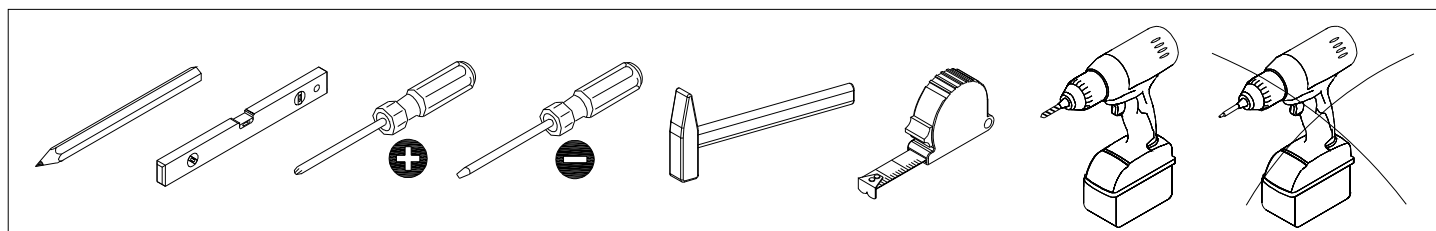

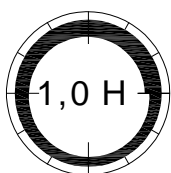

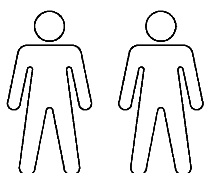

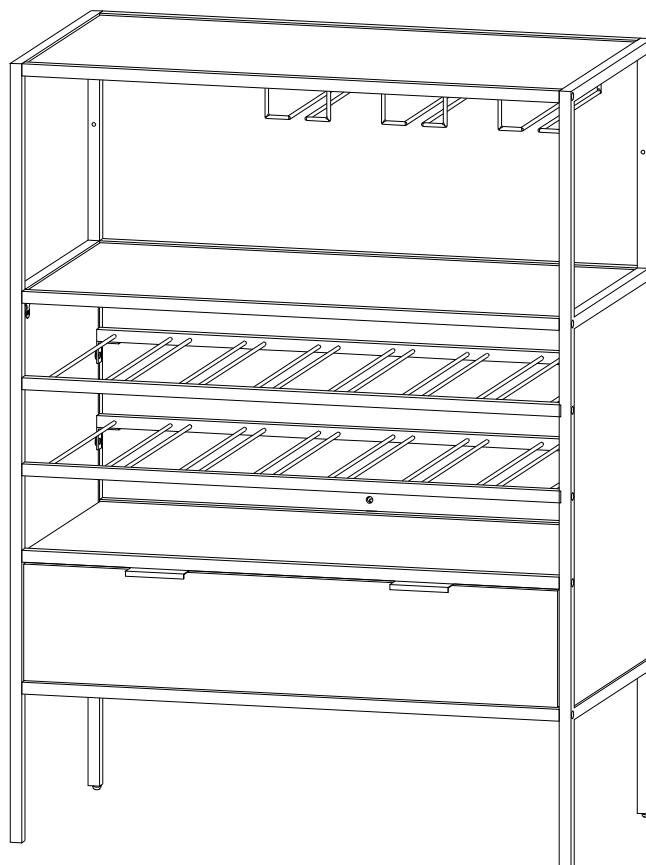

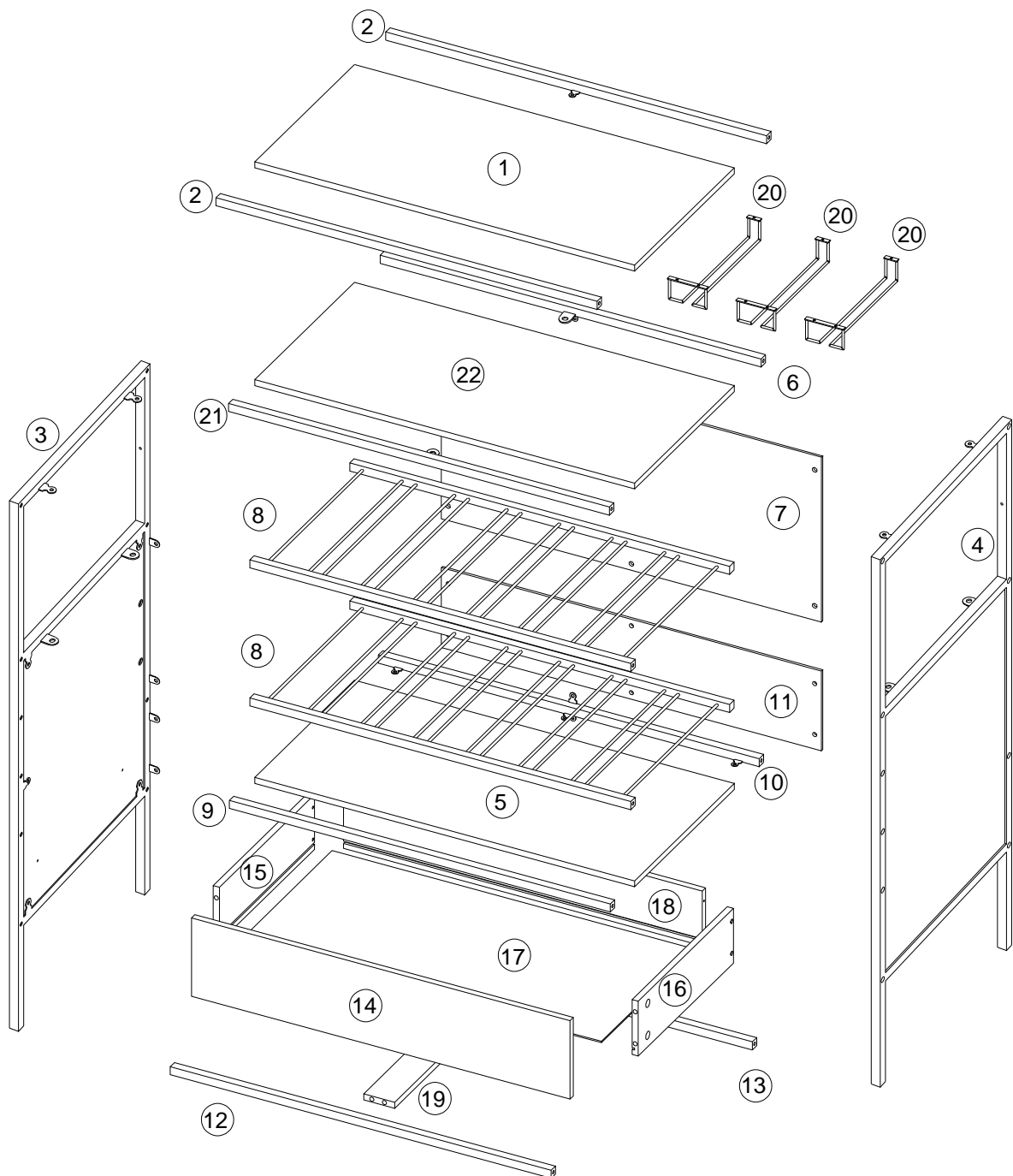

# SEAFORD

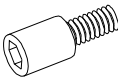
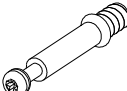

			✓
①	1	737X367X12	
②	2	738X36X16	
③	1	1050X400X40	
④	1	1050X400X40	
⑤	1	737X367X12	
⑥	1	738X40X36	
⑦	1	737X331X4.75	
⑧	2	738X382X16	
⑨	1	738X36X16	
⑩	1	738X36X36	
⑪	1	737X160X4.75	

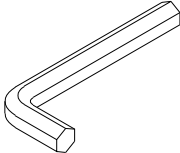
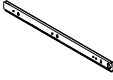
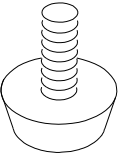
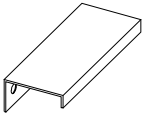
			✓
⑫	1	738X16X16	
⑬	1	738X36X16	
⑭	1	734X156X12	
⑮	1	350X110X12	
⑯	1	350X110X12	
⑰	1	704X347X2.75	
⑱	1	695X110X12	
⑲	1	338X80X12	
⑳	3	265X102X32	
㉑	1	738X40X16	
㉒	1	737X367X12	

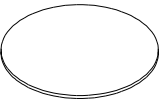

<p>A x 21</p>  <p>Ø3.5×12 mm</p>	<p>B x 8</p>  <p>M6×12 mm</p>	<p>C x 20</p>  <p>Ø6×15 mm</p>	<p>D x 6</p>  <p>Ø6.3×35 mm</p>	<p>E x 6</p>  <p>Ø15×9 mm</p>
<p>F x 6</p>  <p>Ø4×35 mm</p>	<p>G x 12</p>  <p>Ø4×12 mm</p>	<p>H x 12</p>  <p>M6×8 mm</p>	<p>J x 1</p>  <p>4 mm</p>	<p>K x 2</p>  <p>350 mm</p>
<p>L x 2</p>  <p>M6/Ø13 mm</p>	<p>M x 2</p>  <p>80×32×18 mm</p>	<p>N x 4</p>  <p>30×30×15 mm</p>	<p>P x 4</p>  <p>Ø20 mm</p>	<p>Q x 6</p>  <p>M6×10 mm</p>

# 1

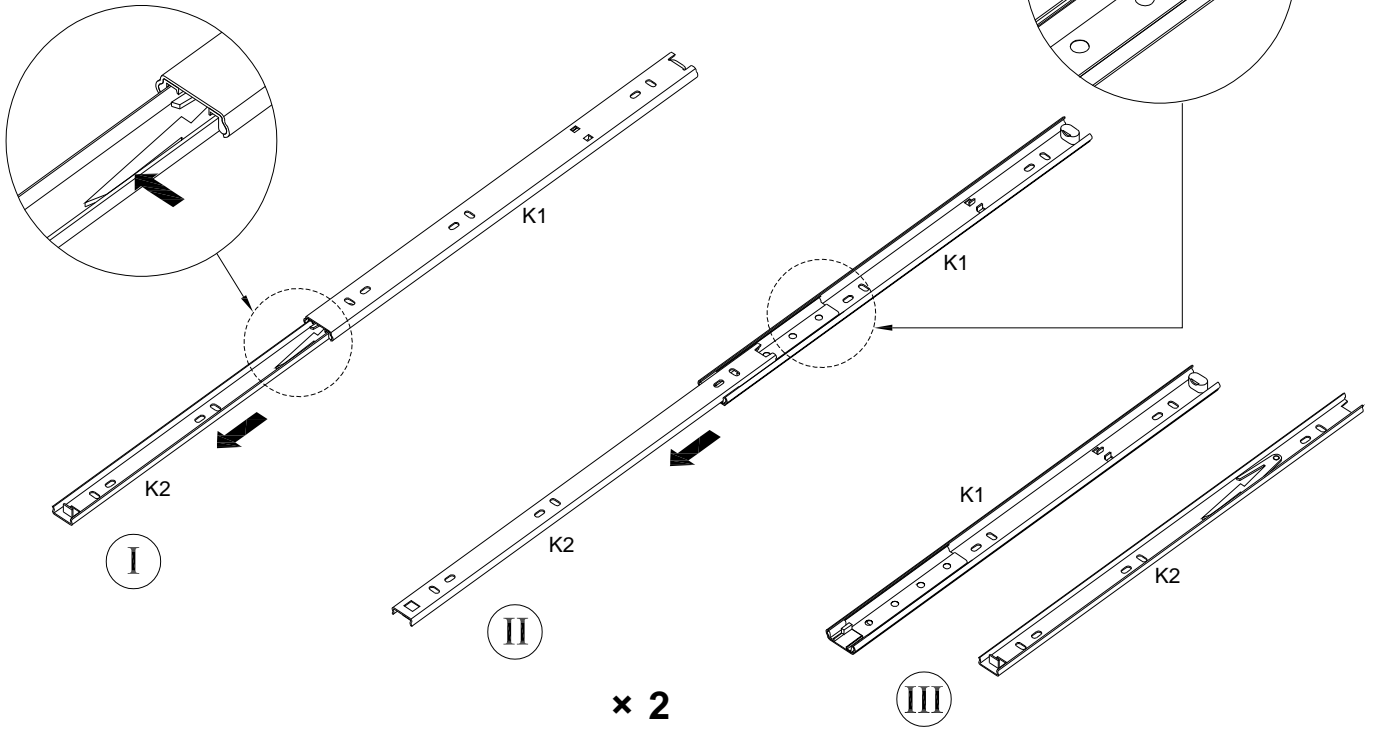
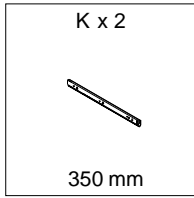

# 2

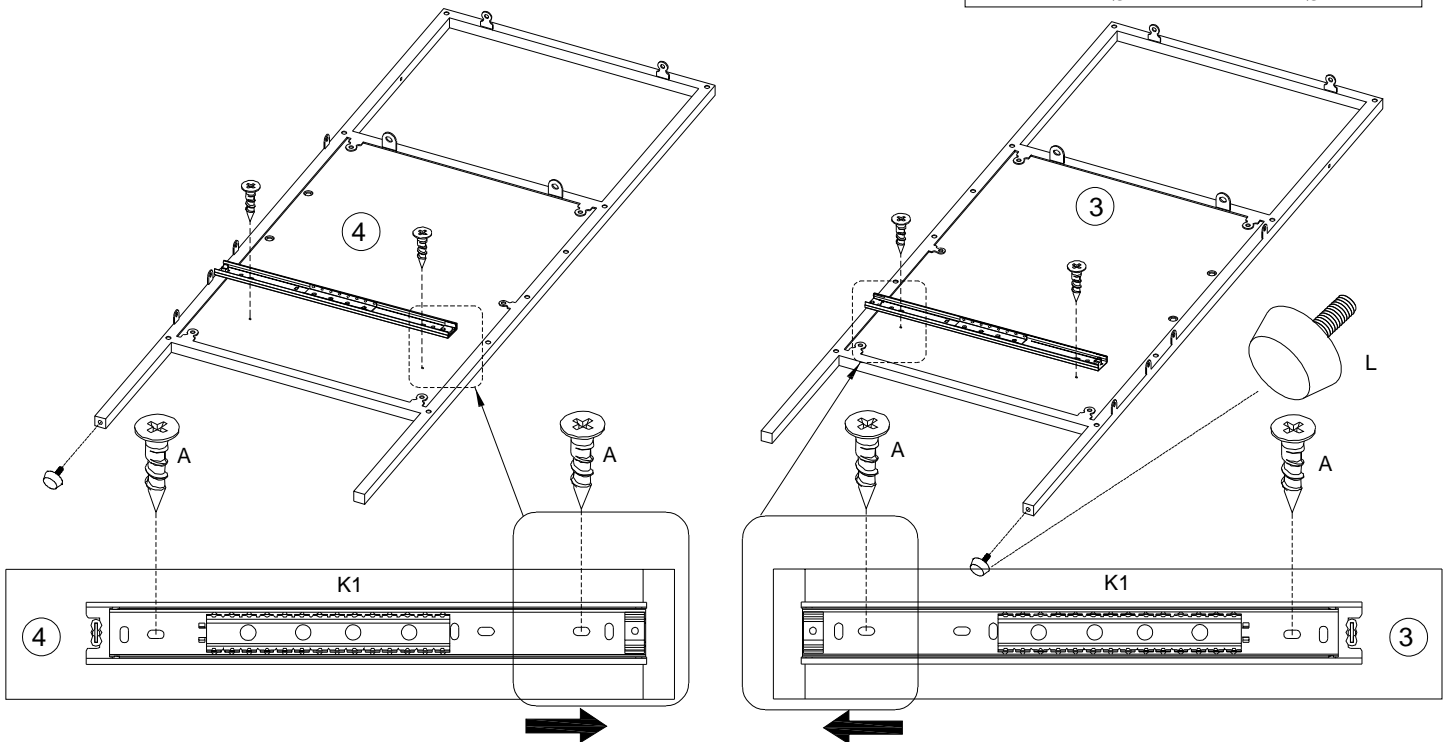
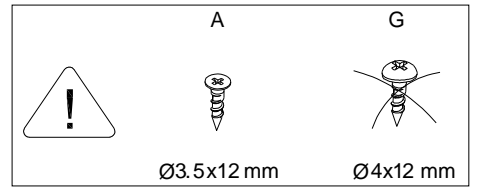
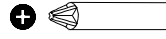
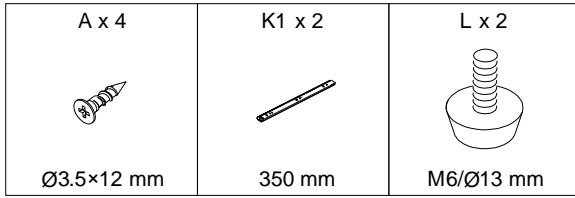

# 3

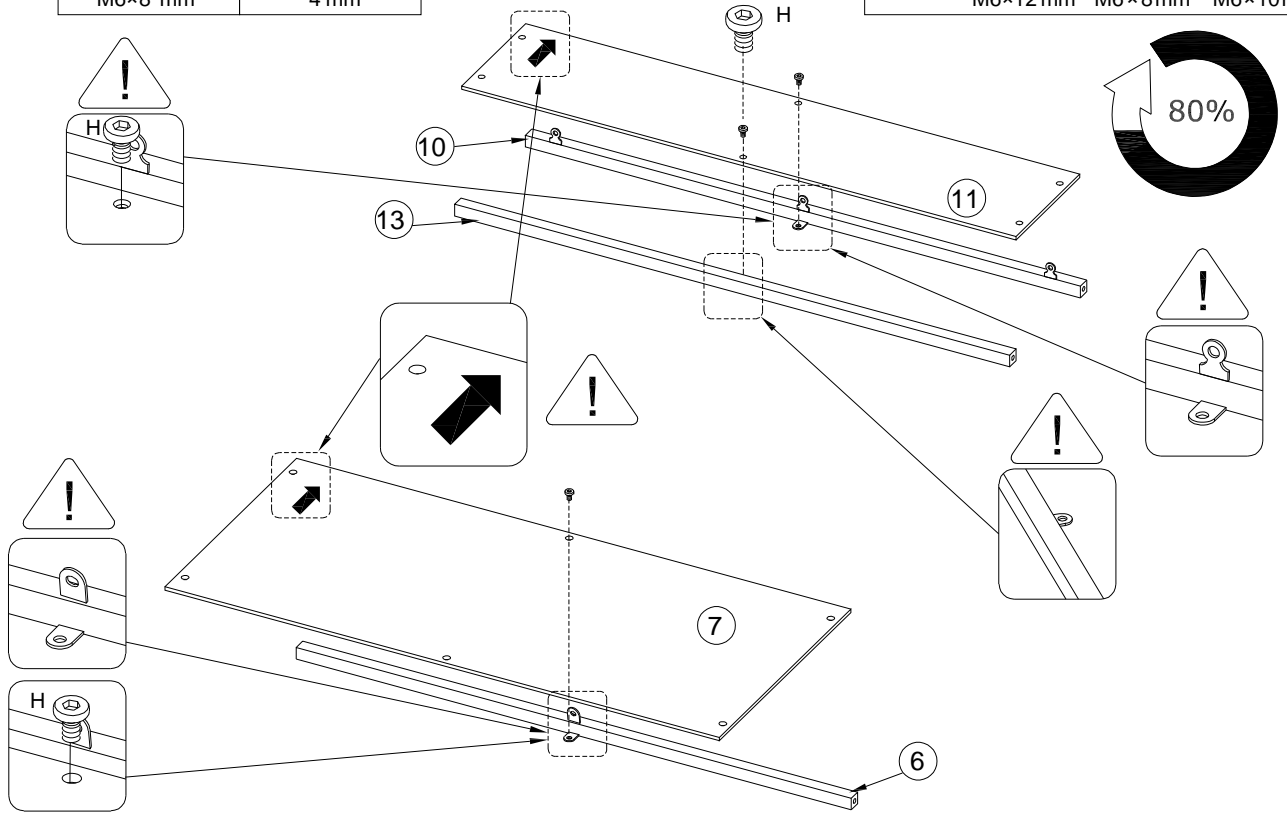
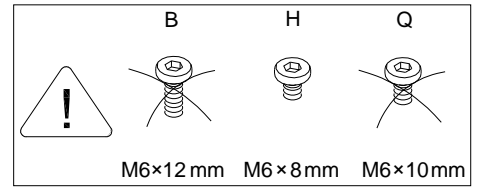
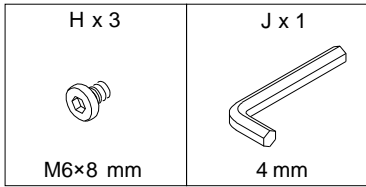

# 4

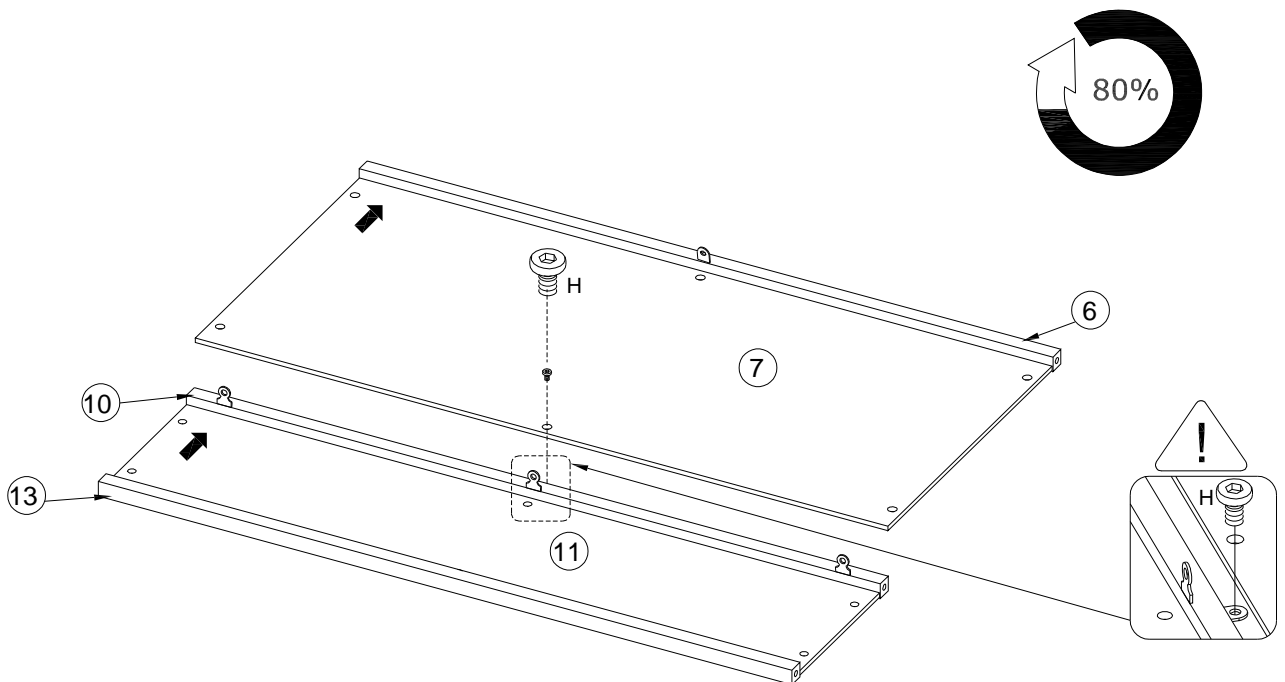
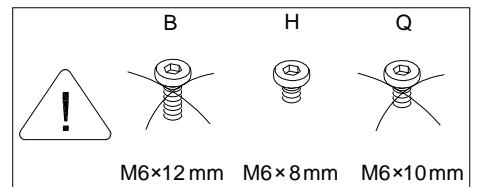
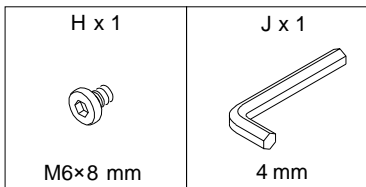



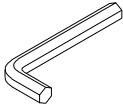

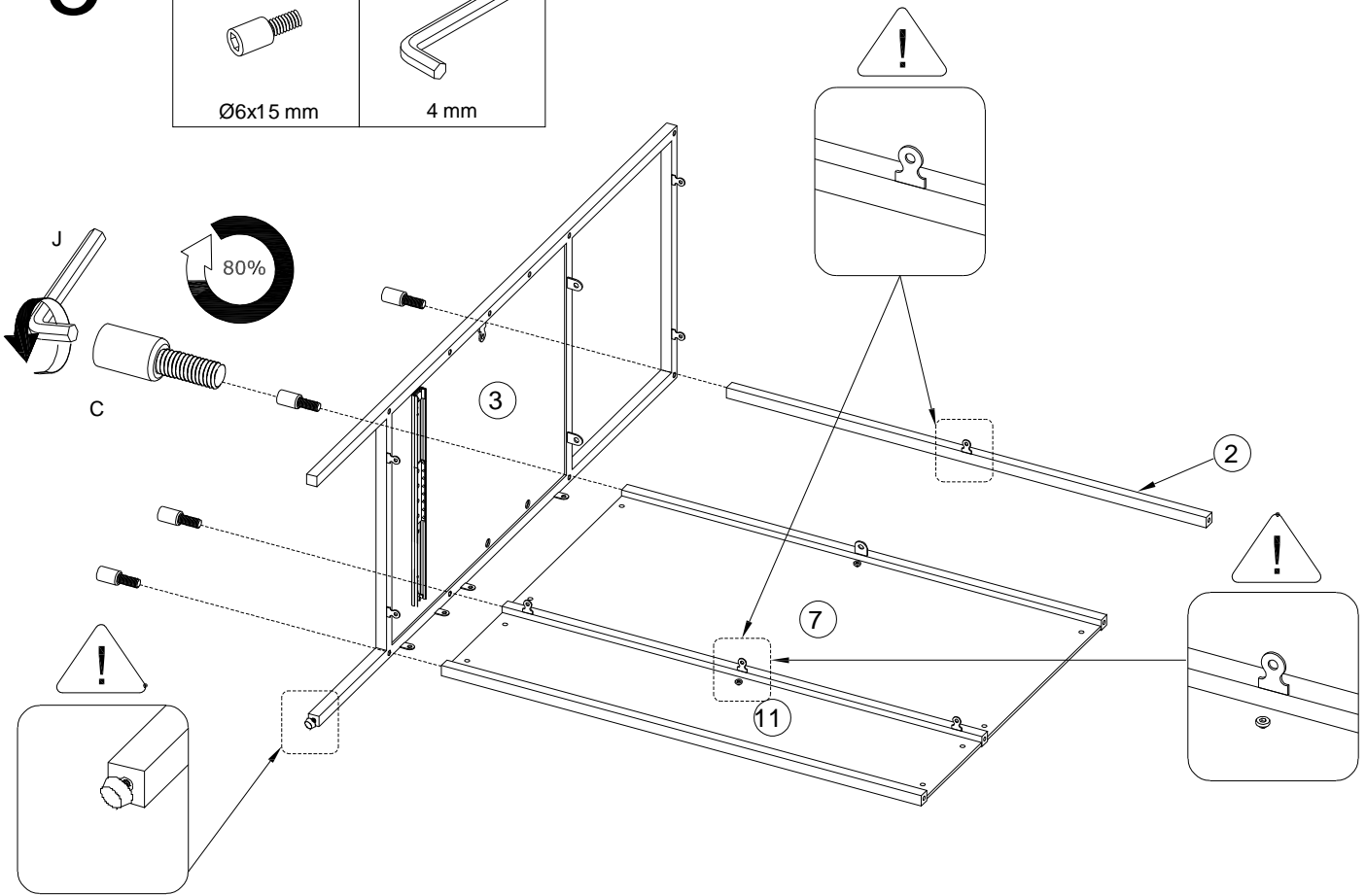
# 5

C x 4	J x 1
	
Ø6x15 mm	4 mm

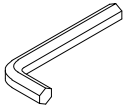



# 6



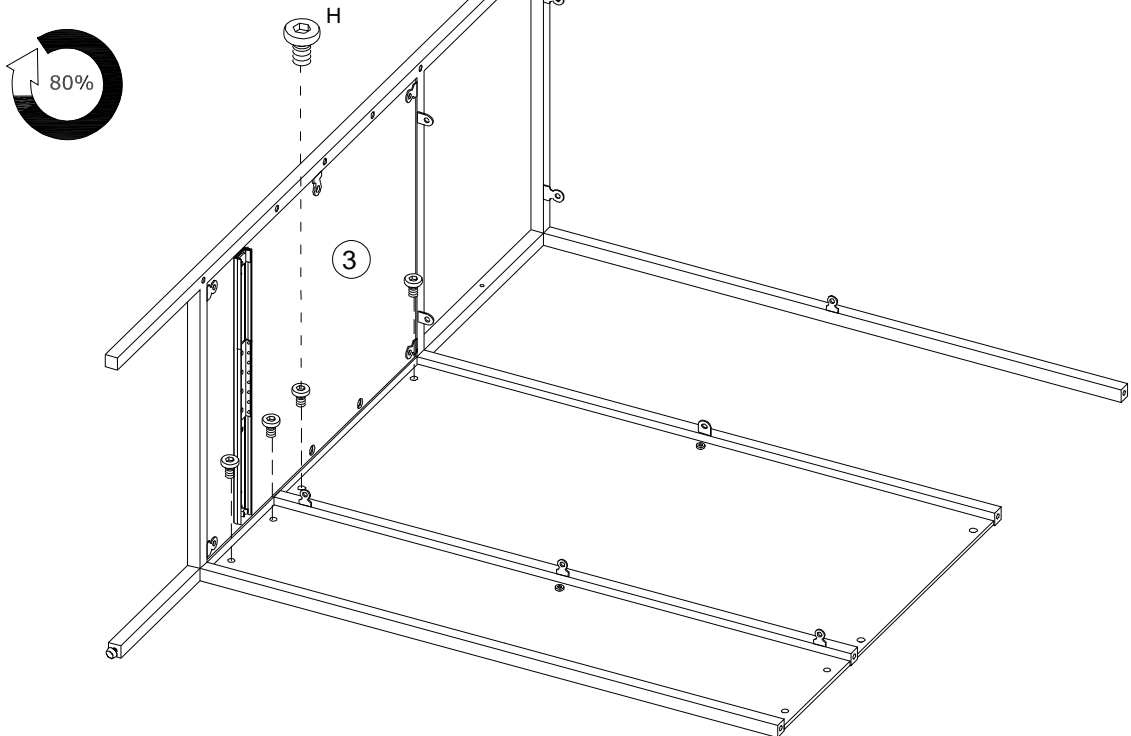

H x 4	J x 1
	
M6x8 mm	4 mm

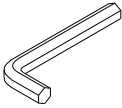
			
	M6x12 mm	M6x8 mm	M6x10 mm



# 7

B x 4  M6x12 mm	J x 1  4 mm	N x 4  30x30x15 mm
--	--	---

	B  M6x12 mm	H  M6x8 mm	Q  M6x10 mm
---	--	---	--

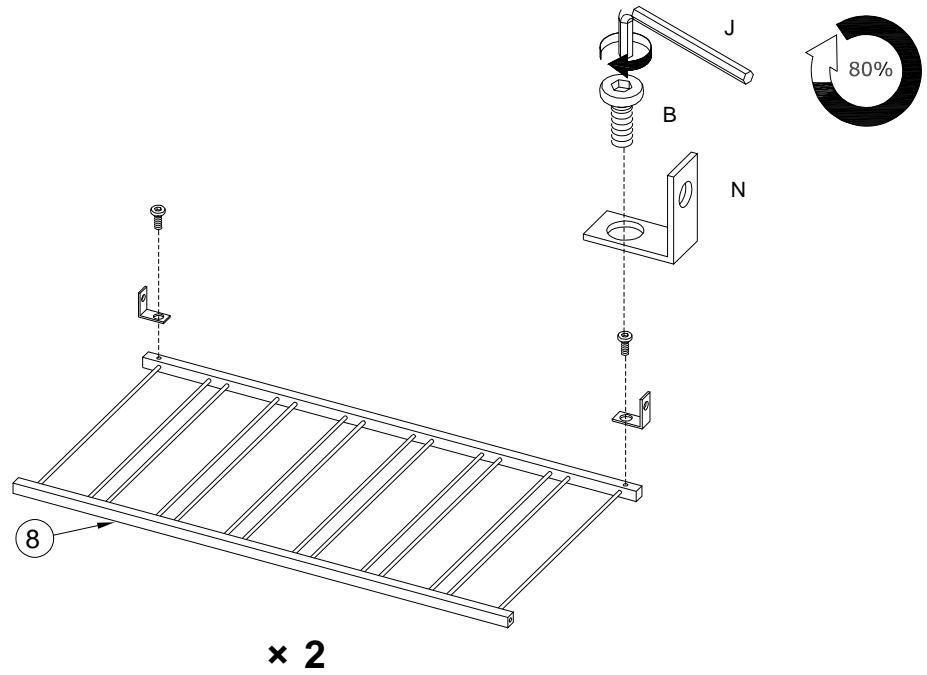



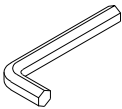

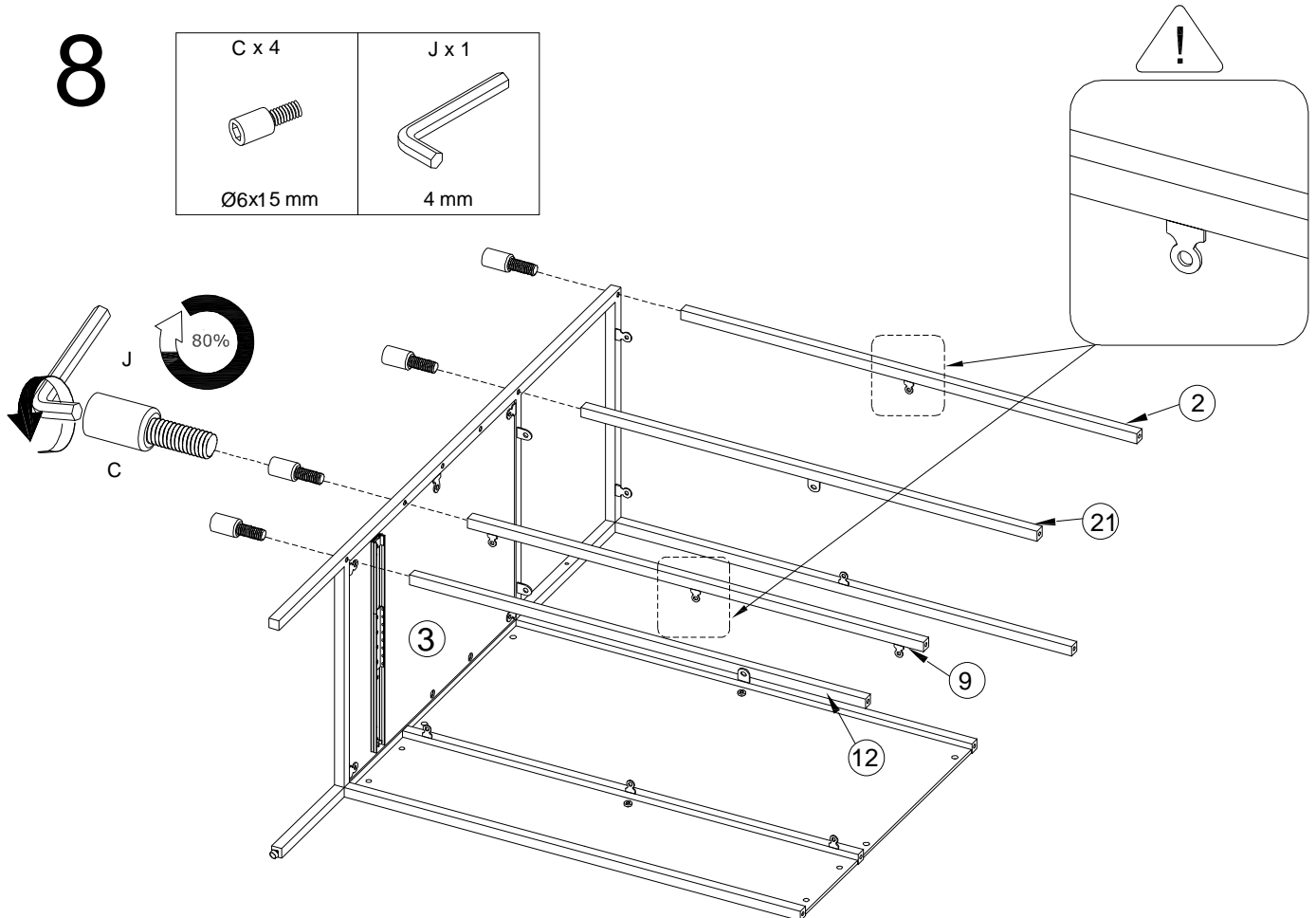

# 8

C x 4  Ø6x15 mm	J x 1  4 mm
--	--

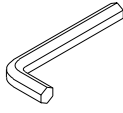

# 9

B x 2	C x 2	J x 1
		
M6x12 mm	Ø6x15 mm	4 mm

	B	H	Q
			
	M6x12 mm	M6x8 mm	M6x10 mm

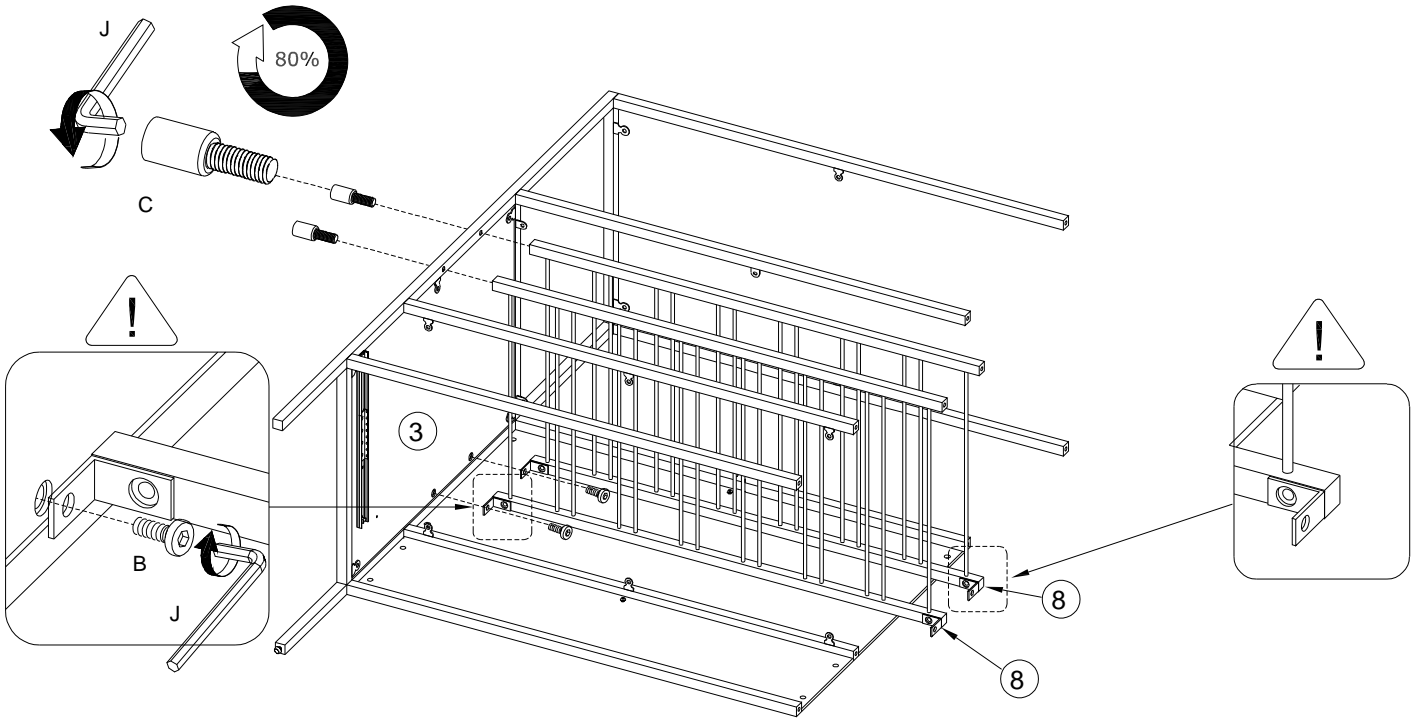

# 10

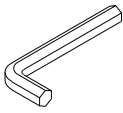
C x 10	J x 1
	
Ø6x15 mm	4 mm

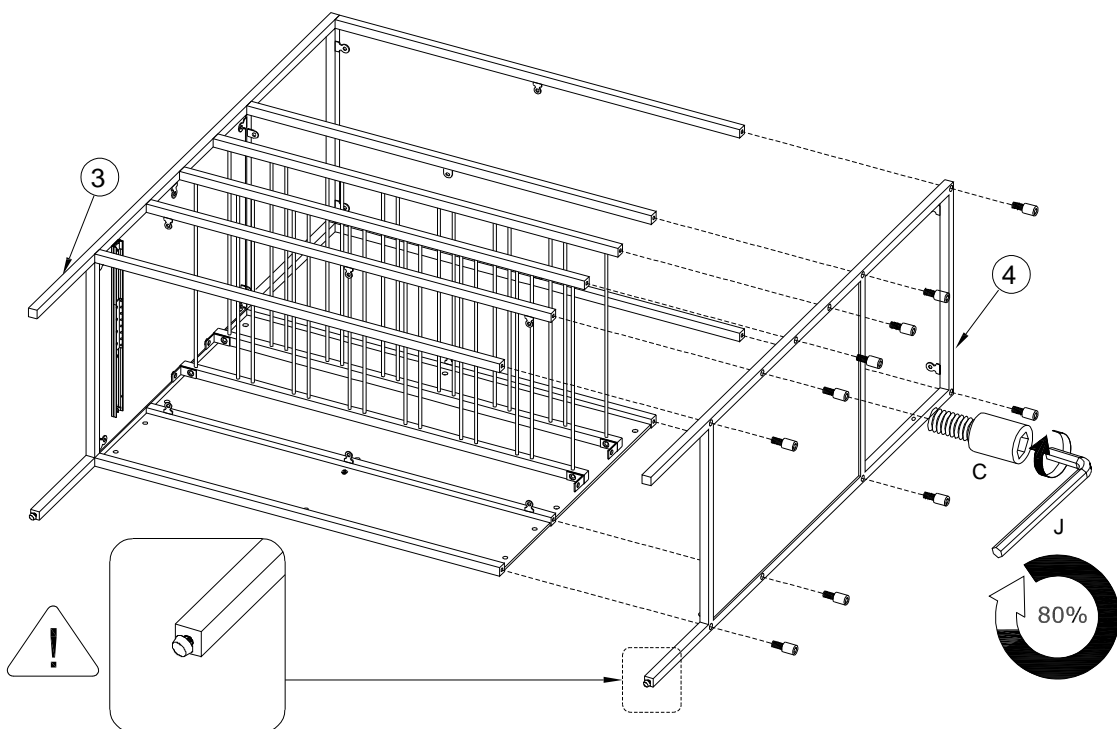



# 11

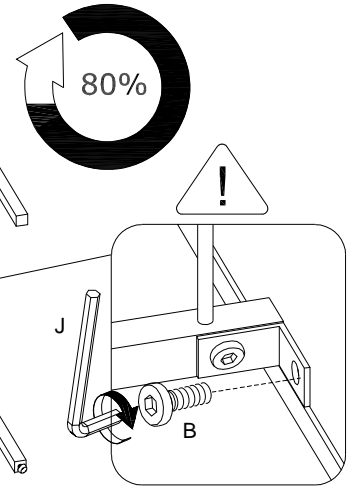
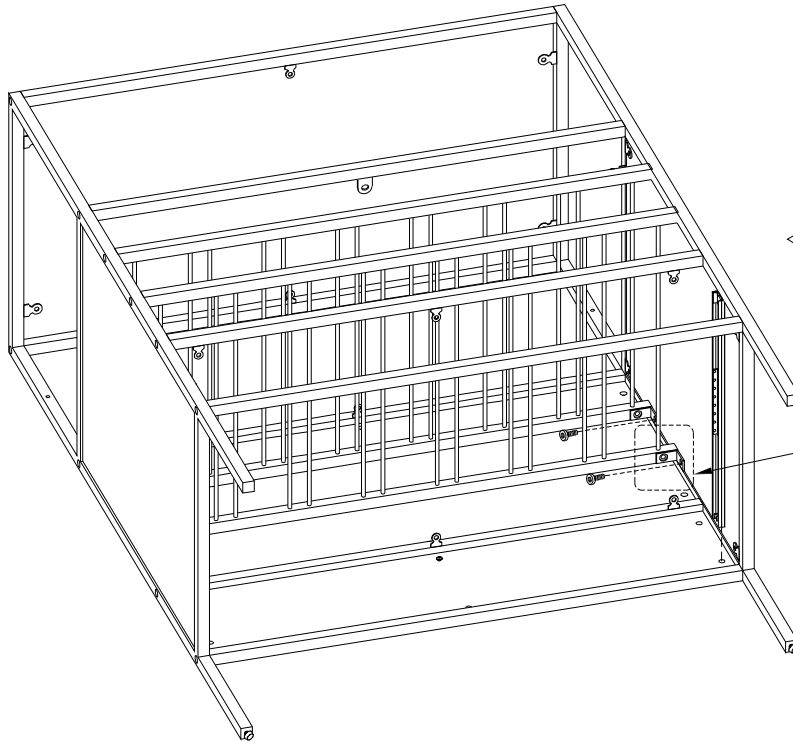
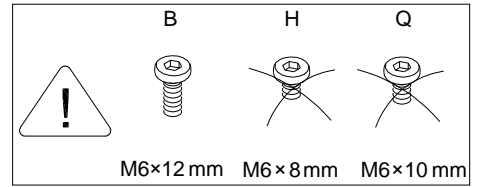
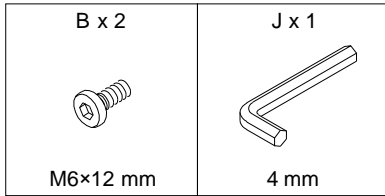

# 12

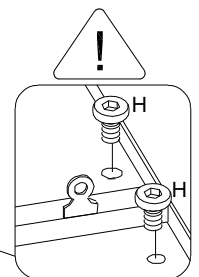
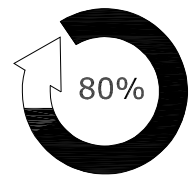
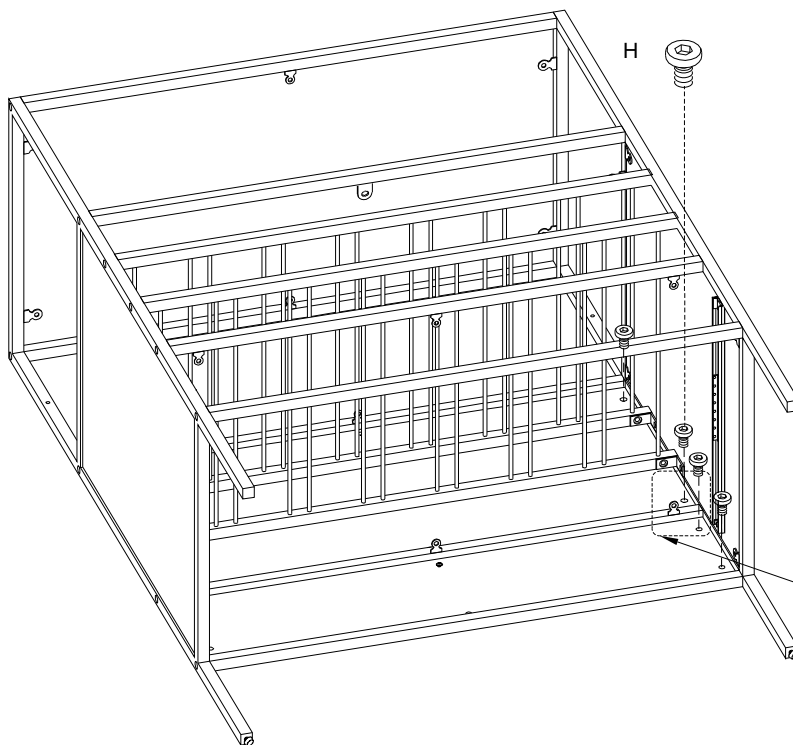
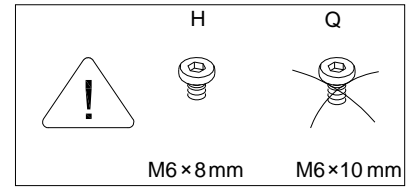
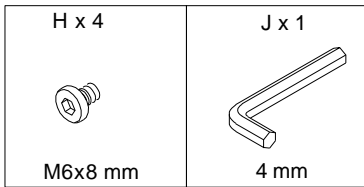

# 13

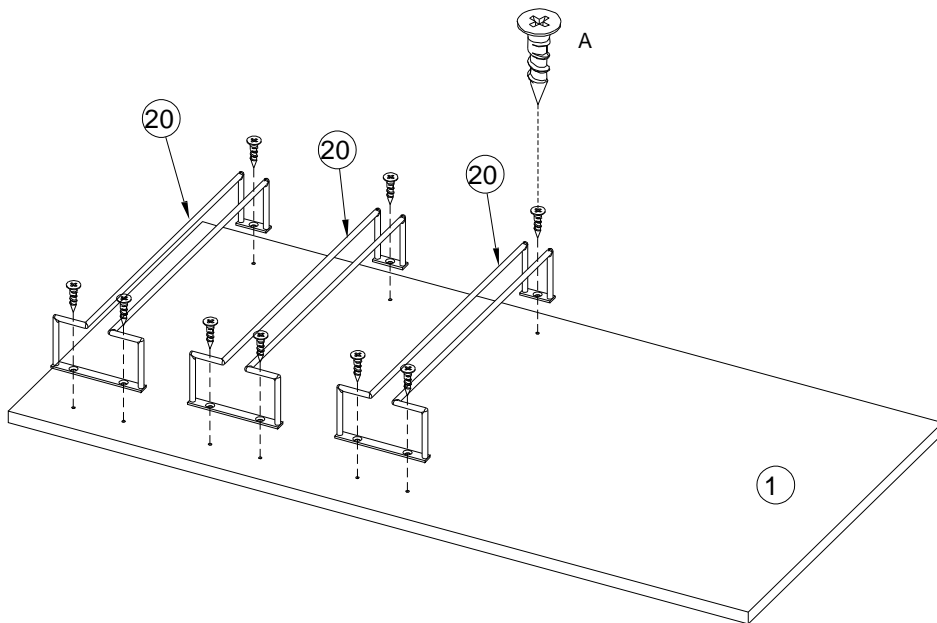
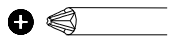
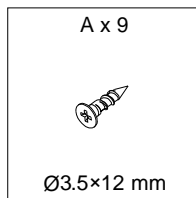

# 14

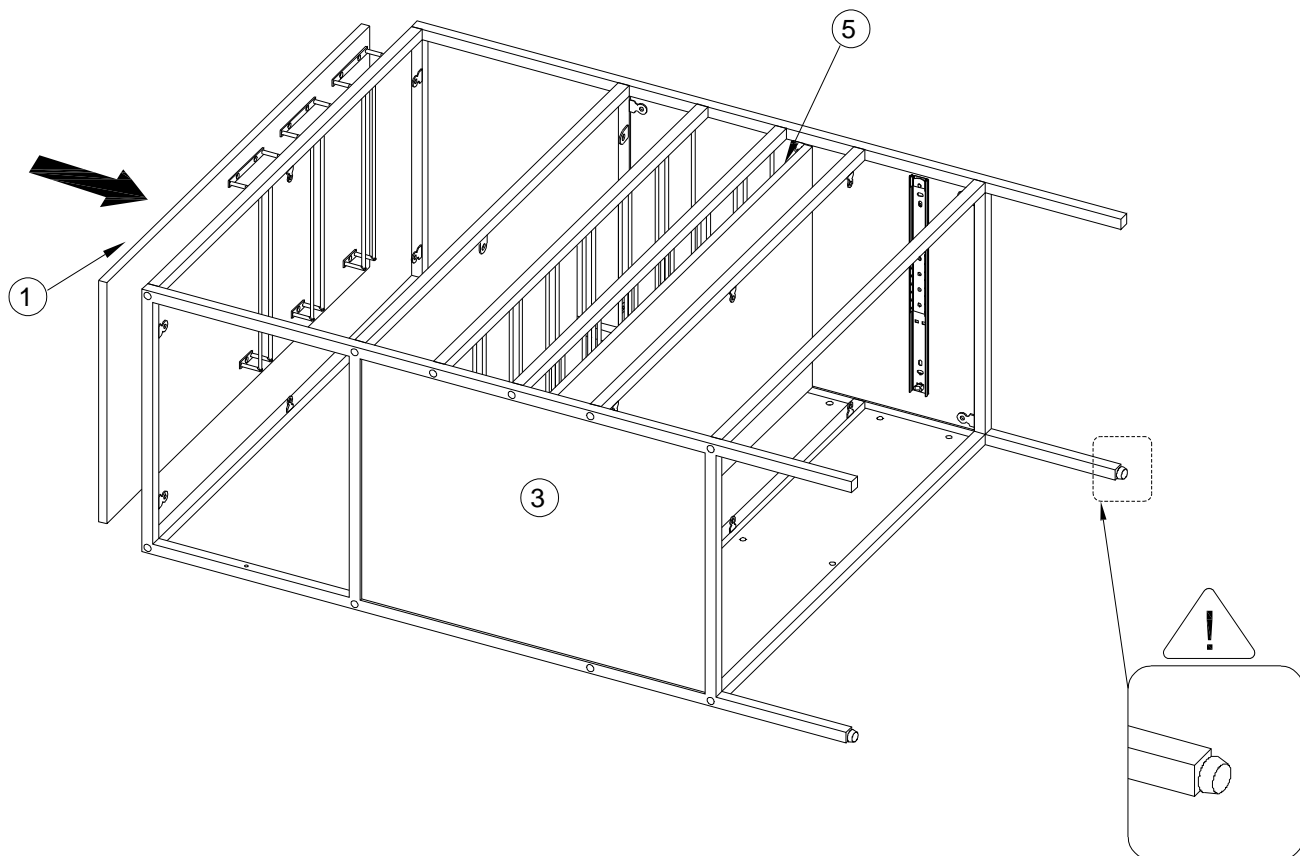

# 15

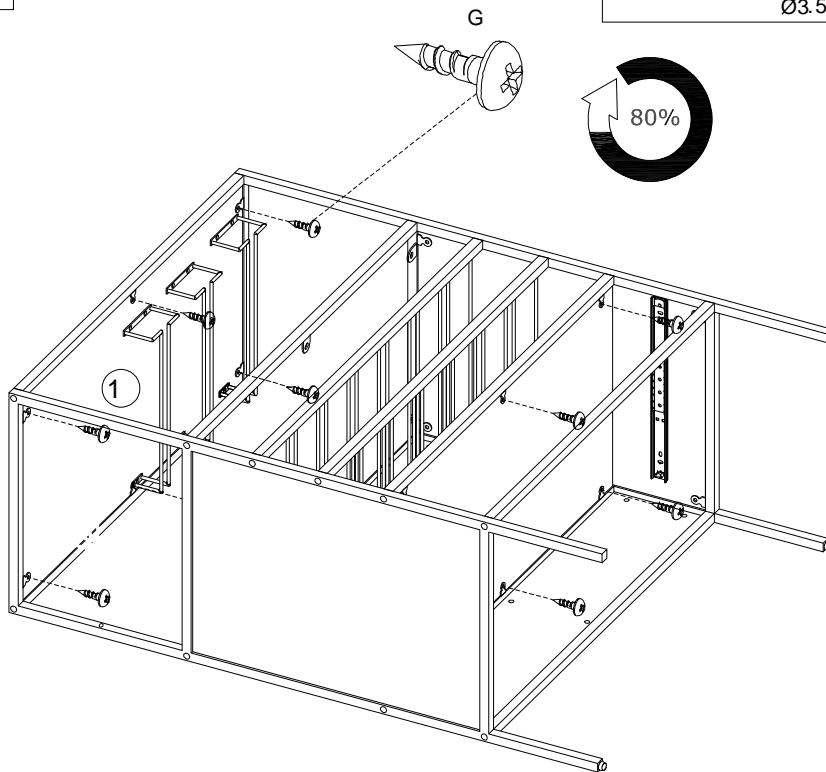
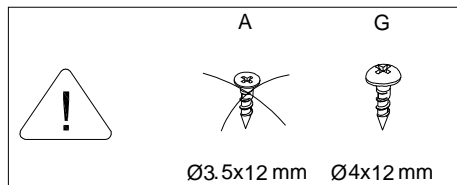
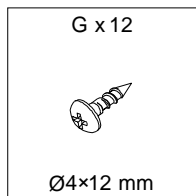

# 16

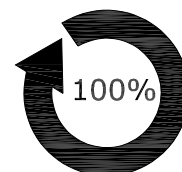
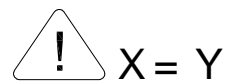
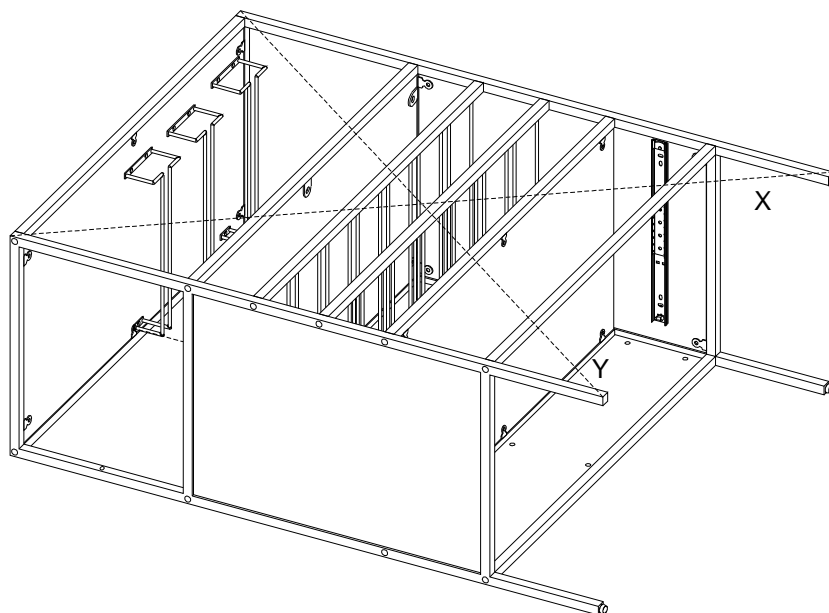
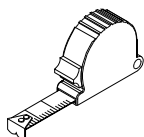

B x 8  
C x 20  
H x 12

# 17

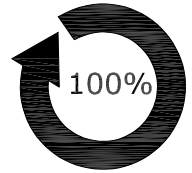
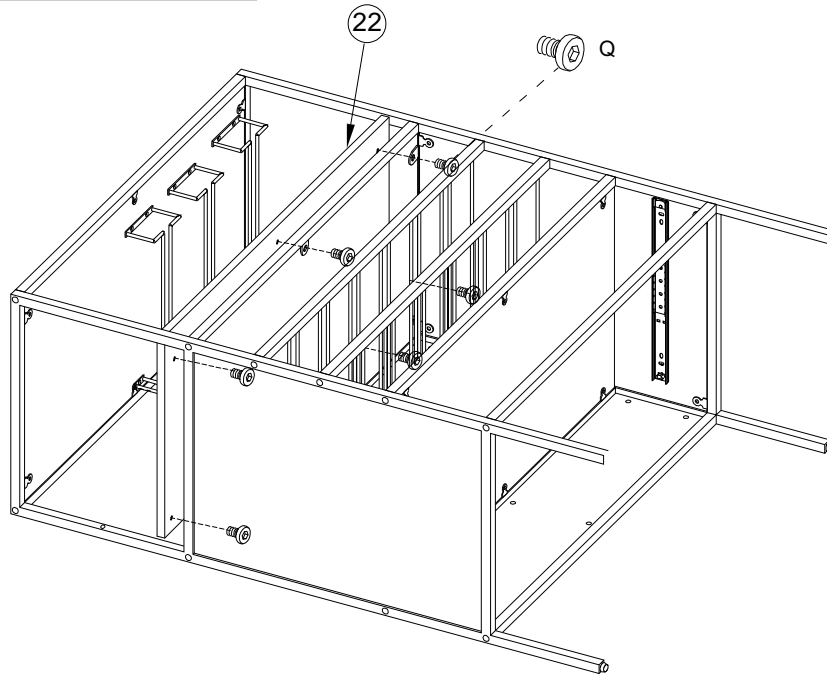
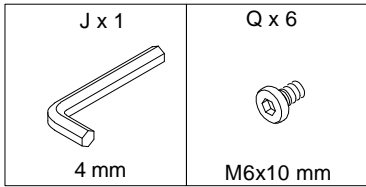

G x 12

# 18

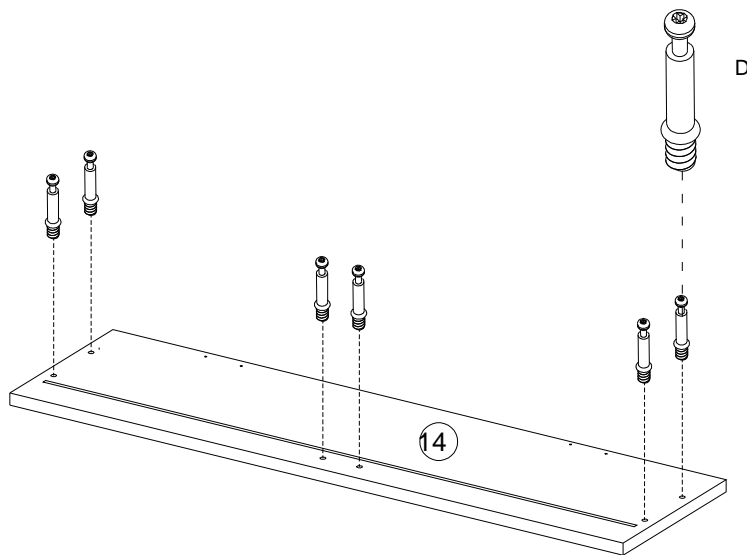
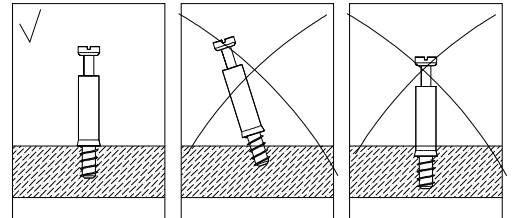
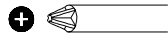
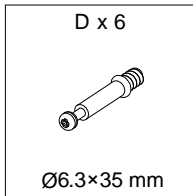

# 19

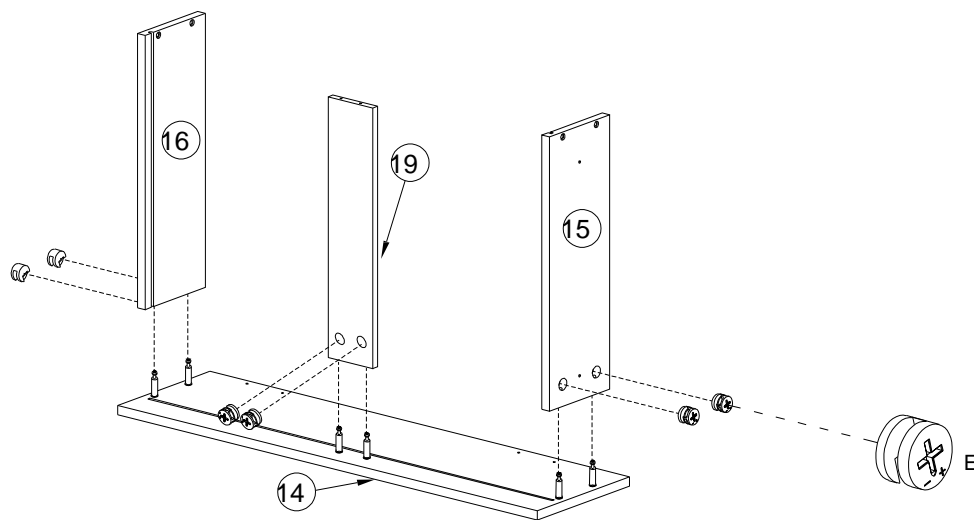
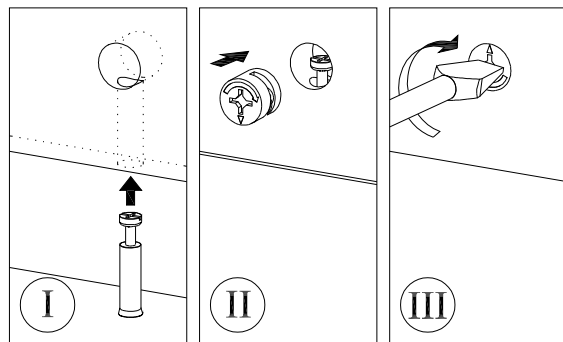
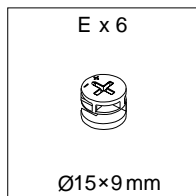

# 20

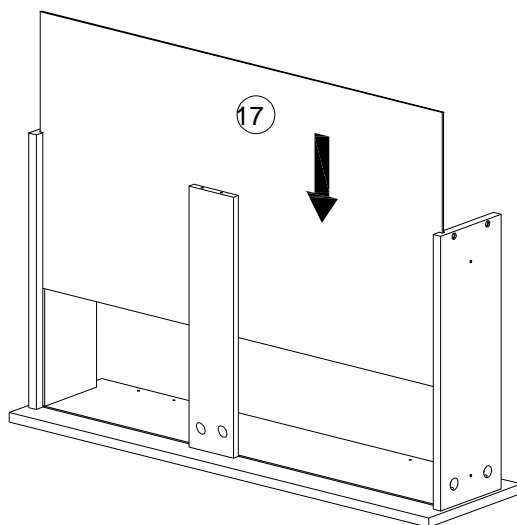

# 21

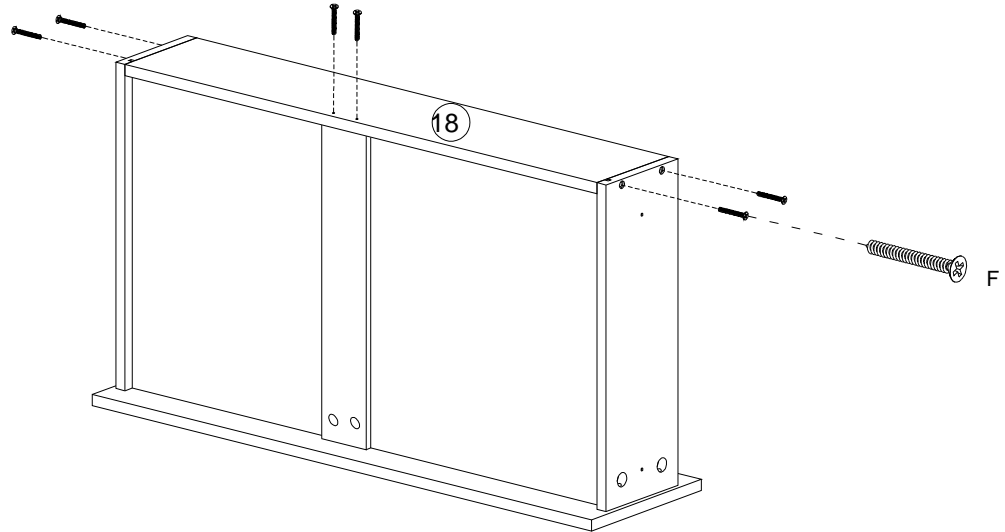
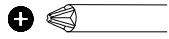
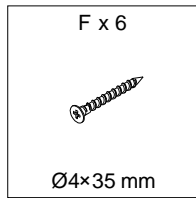

# 22

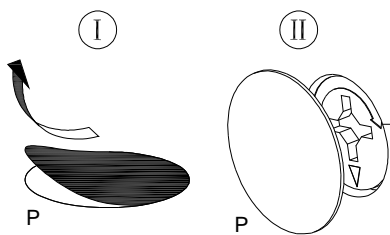
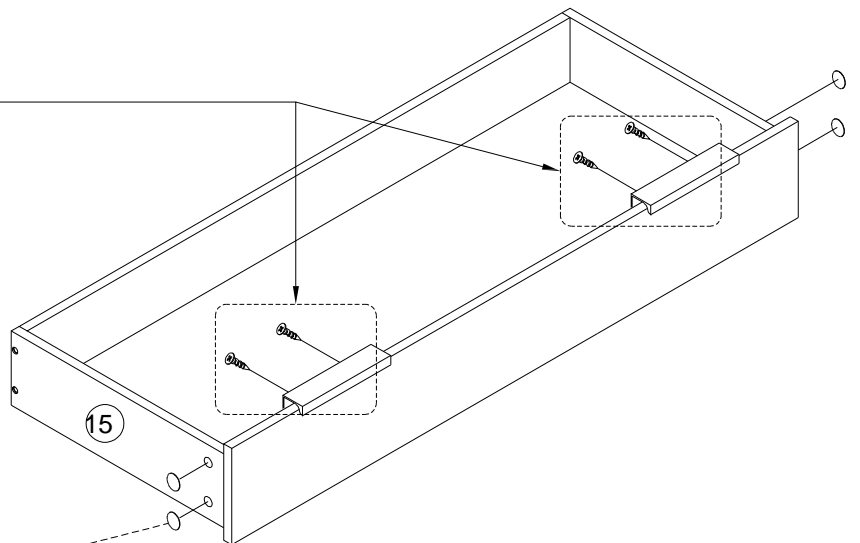
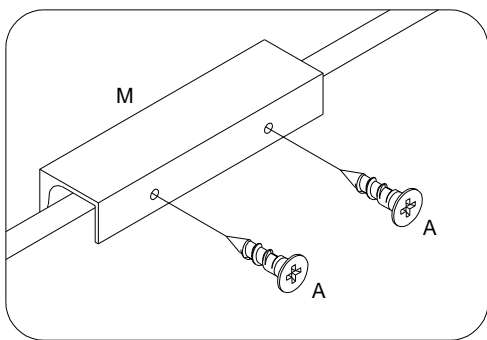
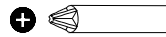
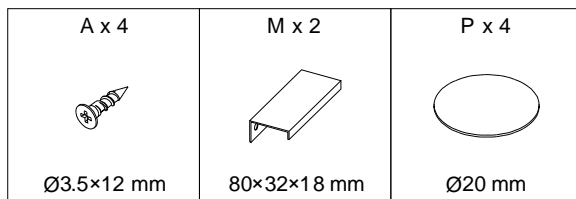

# 23

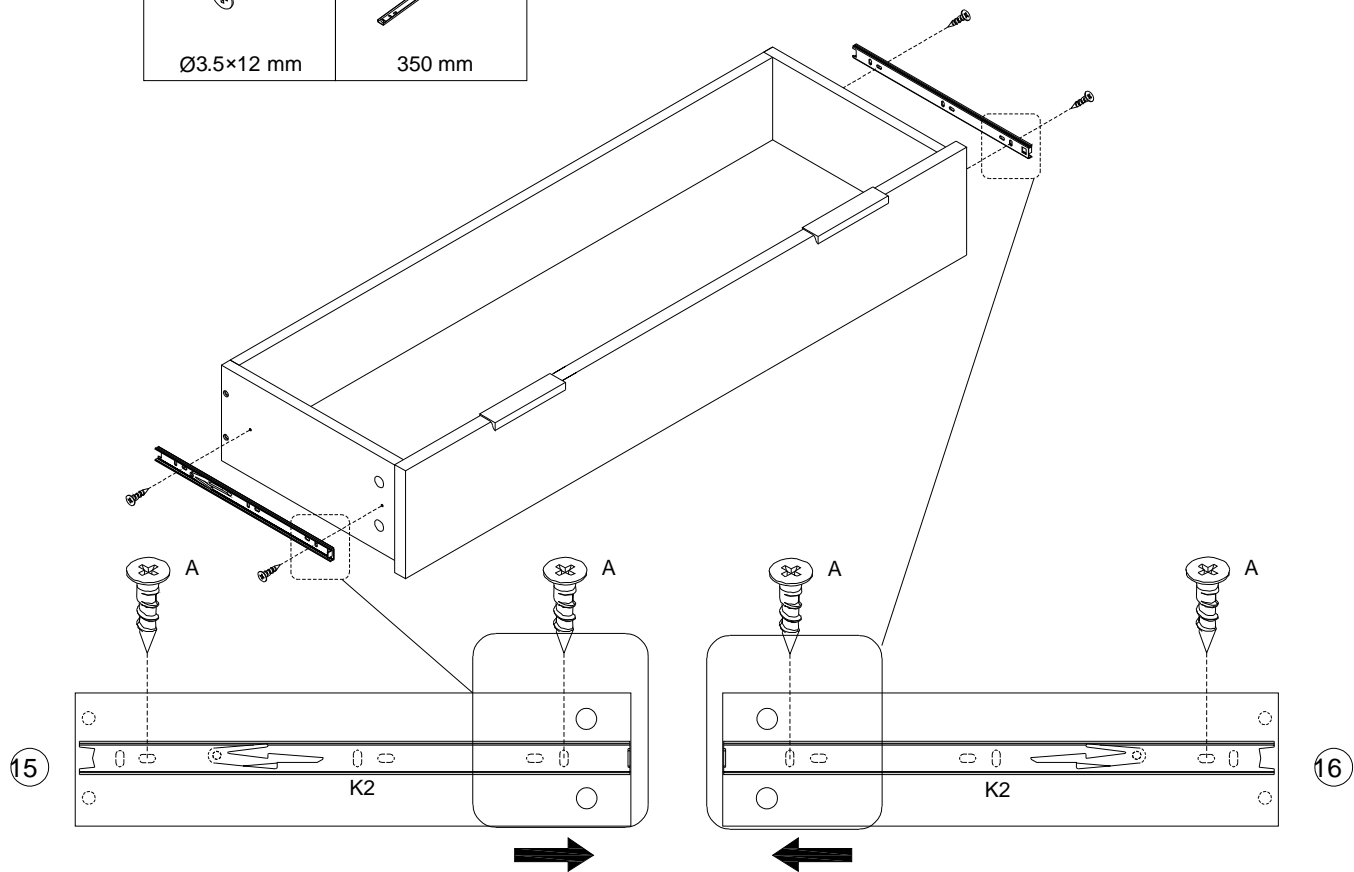
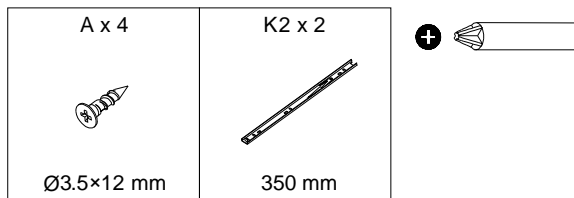

# 24

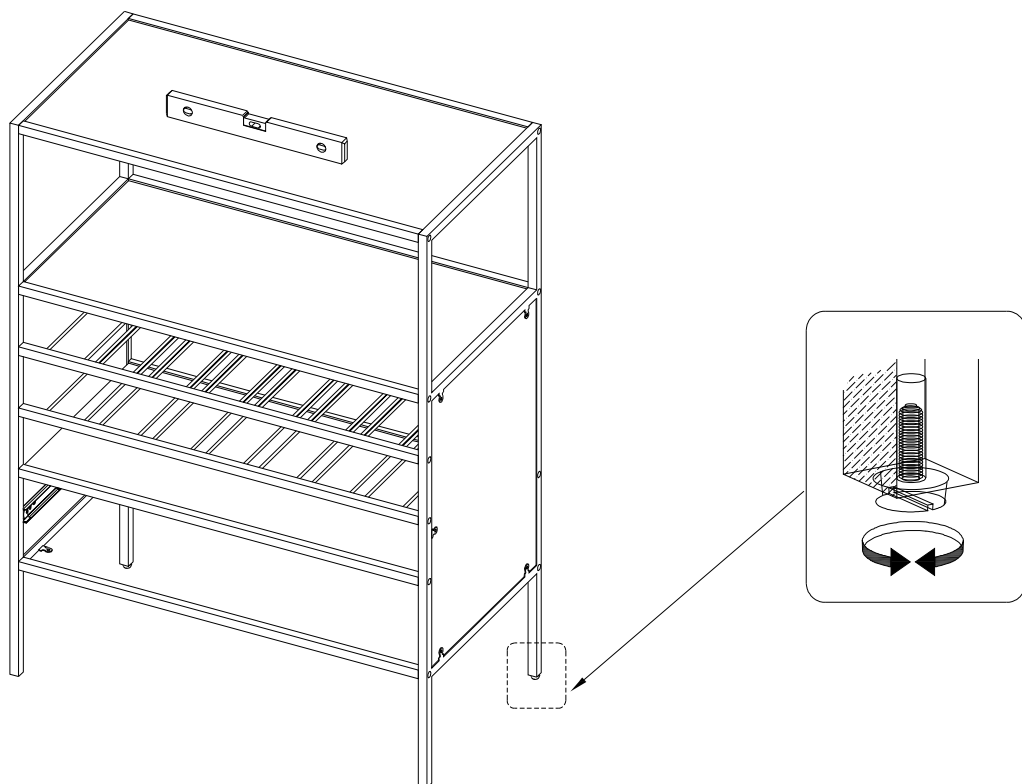
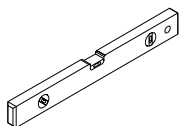

# 25

