



IMPORTANTE - TENERE PER FUTURE CONSULTAZIONI: LEGGERE ATTENTAMENTE
IMPORTANT - RETAIN FOR FUTURE REFERENCE: READ CAREFULLY
IMPORTANTE - ARCHIVAR LAS INSTRUCCIONES PARA CONSULTARLAS MÁS TARDE: LEA ATENTAMENTE
IMPORTANT - À CONSERVER POUR CONSULTATION ULTERIEURE: LIRE ATTENTIVEMENT
WICHTIG - FÜR ZUKUNFT REFERENZ AUFBEWAHREN: BITTE ES SORGFÄLTIG ZU LESEN







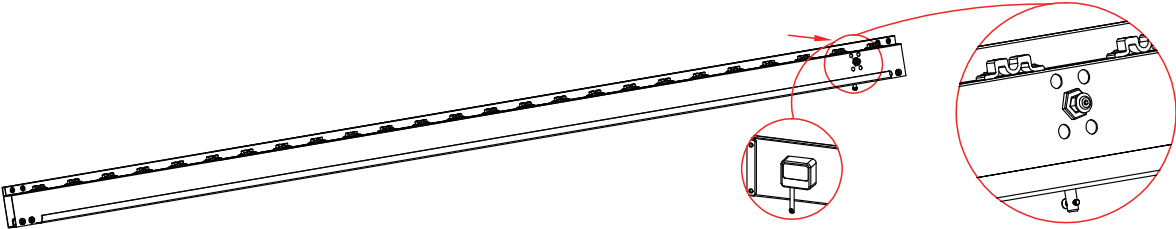
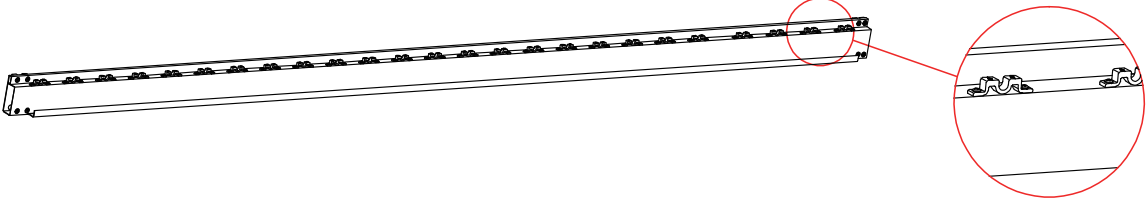
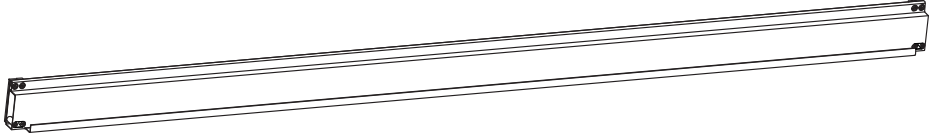
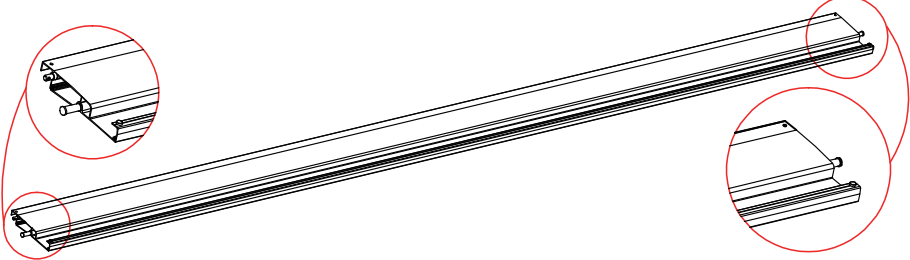
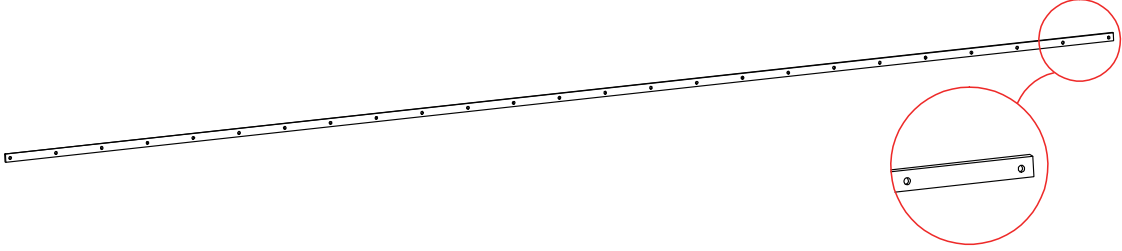

2 hours

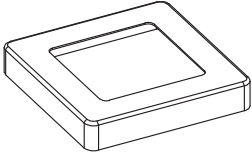
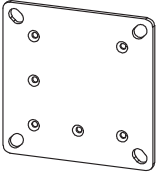
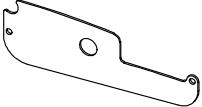
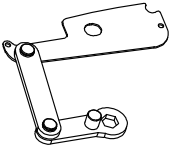
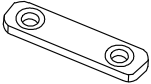
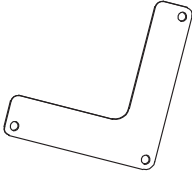
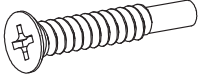
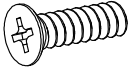

	REF	QTY	REF	QTY	REF	QTY
Carton 1/4	(A)	4PCS	(I)	4PCS	(J)	4PCS
	(K)	51PCS	(L)	1PC	(M)	52PCS
	(N)	4PCS	(O)	24PCS	(P)	104PCS
	(Q)	104PCS	(R)	12PCS	(S)	29PCS
	(V)	1PC	(W)	16PCS	(X)	1PC
	(Y)	2PCS	(Z)	1PC		
	User Manual	1SET				
Carton 2/4	(B1)	1PC	(B2)	1PC	(C)	2PCS
	(G)	1PC	(H)	1PC		
Carton 3/4	(D)	13PCS				
Carton 4/4	(D)	12PCS				

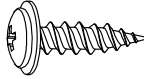
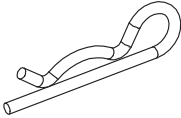
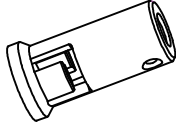
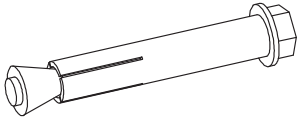
REF	PICTURE	QTY
A		4PCS
B1		1PC
B2		1PC
C		2PCS
D		25PCS
G		1PC
H		1PC

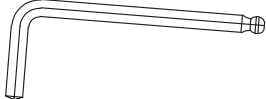
REF	PICTURE	QTY
I		4PCS
J		4PCS
K		51PCS
L		1PC
M		52PCS
N		4PCS
O		24PCS
P	 M5x12mm	104PCS
Q	 4.2x25mm	104PCS

REF	PICTURE	QTY
R	 5.5x19mm	12PCS
S		29PCS
V		1PC
W		16PCS
X		1PC
Y		2PCS
Z	 Ø12mm	1PC

IT

AVVERTENZE
IN CASO DI NEVE, POSIZIONARE LE
LAMELLE IN POSIZIONE VERTICALE
PER EVITARE DANNI ALLA PERGOLA.

EN

WARNING
IN SNOW SEASON OR IN CASE
OF SNOW FORECAST OPEN UP
YOUR SHUTTERS IN VERTICAL
POSITION TO AVOID ANY
DAMAGING ON YOUR
PERGOLA.

ES

ADVERTENCIA
EN CASO DE NIEVE, COLOQUE LAS
LAMAS EN POSICIÓN VERTICAL
PARA EVITAR DAÑAR LA PÉRGOLA.

FR

AVERTISSEMENTS
EN CAS DE NEIGE, PLACER LES
LAMELLES EN POSITIONS
VERTICALE POUR ÉVITER
D'ENDOMMAGER LA TONNELLE.

DE

WARNUNGEN
BEI SCHNEEFALL DIE LAMELLEN
SENKRECHT STELLEN, UM SCHÄDEN
AN DER PERGOLA ZU VERMEIDEN.

IT

PRIMA DI PROCEDERE CON IL
MONTAGGIO, ASSICURARSI DI
POSIZIONARE IL PRODOTTO SU
UNA SUPERFICIE PIANA E PULITA
E UTILIZZARE UN TELO MORBIDO
D'APPOGGIO DURANTE L'ASSEM-
BLAGGIO. QUESTO PER EVITARE
URTI E DANNI AL PRODOTTO
DURANTE IL MONTAGGIO. NON
STRINGERE LE VITI FINCHÉ
NON SONO NELLA POSIZIONE
CORRETTA.

EN

BEFORE PROCEEDING WITH
THE ASSEMBLY, MAKE SURE
TO PLACE THE PRODUCT ON
A FLAT AND CLEAN SURFACE
AND USE A SOFT COVER
DURING ASSEMBLY TO AVOID
IMPACTS AND DAMAGE
TO THE PRODUCT. DON'T
TIGHTEN THE SCREWS UNTIL
ALL OF THEM ARE IN THE
RIGHT POSITION.

ES

ANTES DEL MONTAJE,
ASEGÚRESE DE COLOCAR
EL PRODUCTO SOBRE UNA
SUPERFICIE LIMPIA Y PLANA
Y USE UNA TELA SUAVE COMO
SOPORTE PARA EVITAR GOLPES
Y DAÑOS AL PRODUCTO DURAN-
TE EL MONTAJE. NO APRIETE
LOS TORNILLOS HASTA QUE SE
ENCUENTREN EN LA POSICIÓN
CORRECTA.

FR

AVANT DE PROCÉDER À L'AS-
SEMBLAGE, ASSUREZ-VOUS DE
PLACER LE PRODUIT SUR UNE
SURFACE PLANE ET PROPRE ET
D'UTILISER UN TISSU SOUPLE
DE SUPPORT POUR ÉVITER DES
COUPS ET DES DOMMAGES AU
PRODUIT PENDANT L'ASSEM-
BLAGE. NE SERREZ PAS LES VIS
JUSQU'À CE QU'ELLES SOIENT
TOUTES DANS LA POSITION
CORRECTE.

DE

VOR DEM AUFBAU BITTE DAS
PRODUKT AUF EINE EBENE
UND SAUBERE FLÄCHE STELLEN
UND ES EMPFIEHLT SICH, DAS
PRODUKT AUF EINE WEICHE
DECKE AUFZUBAUEN. SO WIRD
VERHINDERT, DASS BEIM AUFBAU
BESCHÄDIGUNGEN UND BEULEN
AM PRODUKT ENTSTEHEN.
SOLANGE ALLE SCHRAUBEN NICHT
IN DER RICHTIGEN POSITION SIND,
NICHT ANZIEHEN.

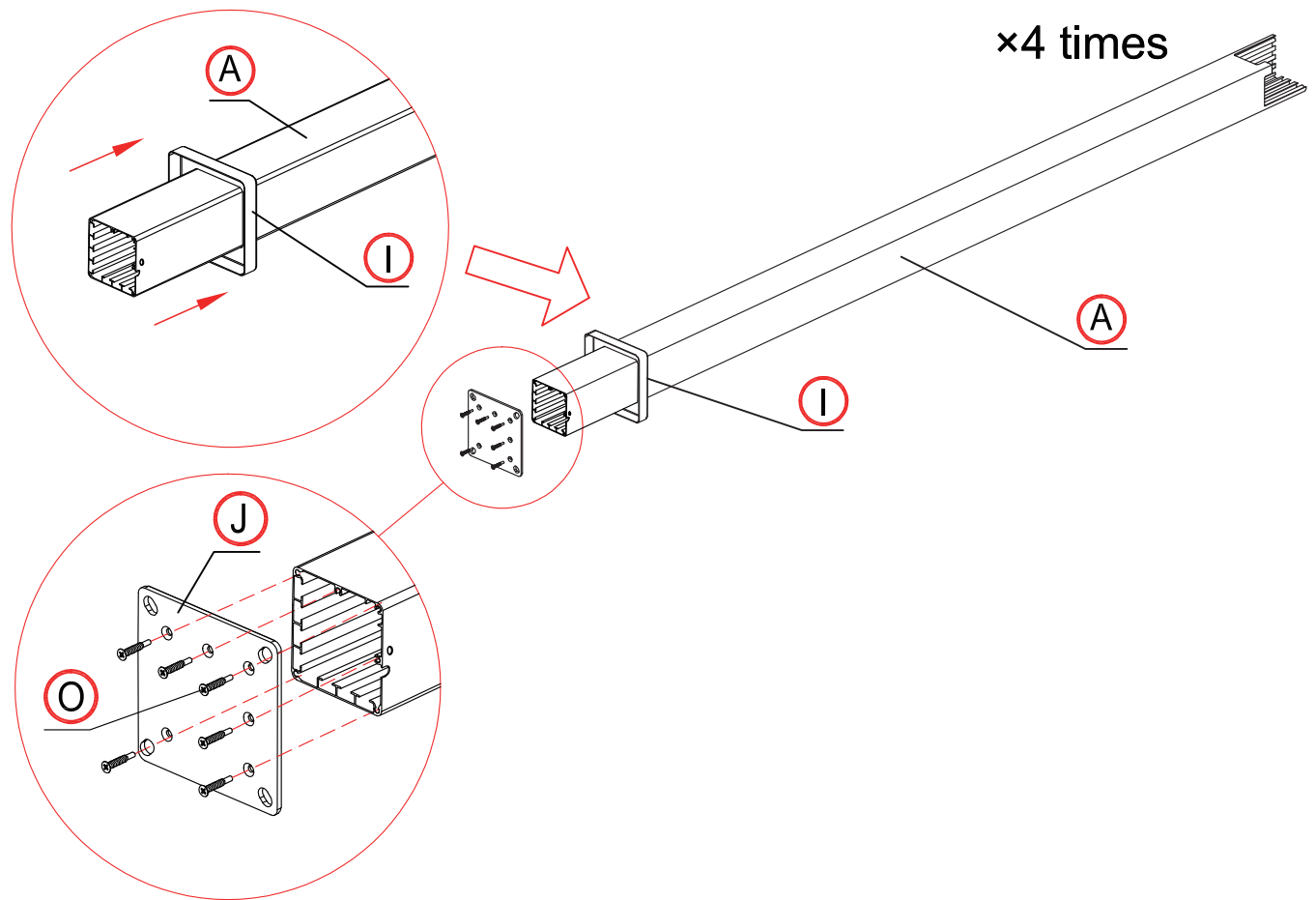

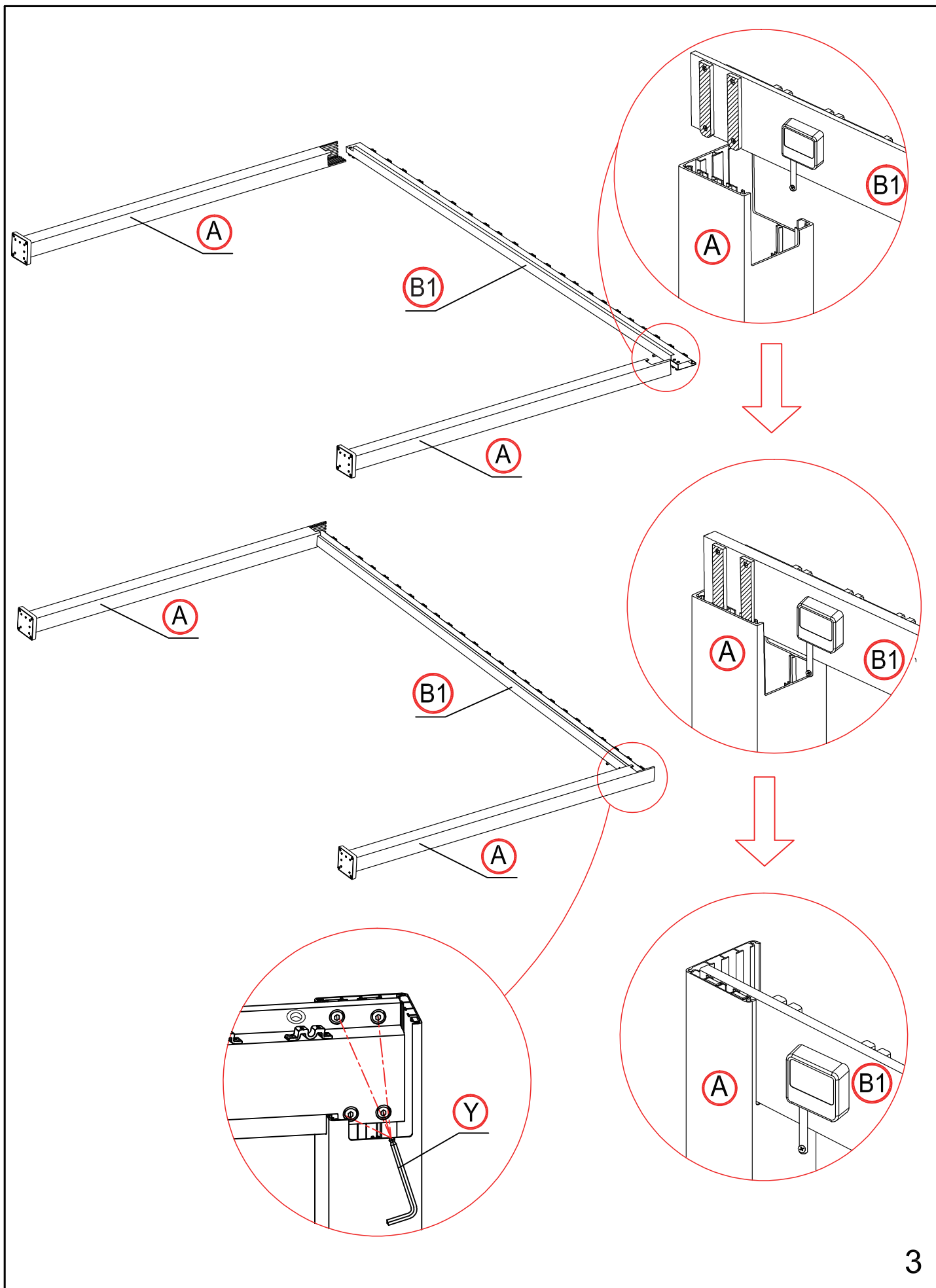

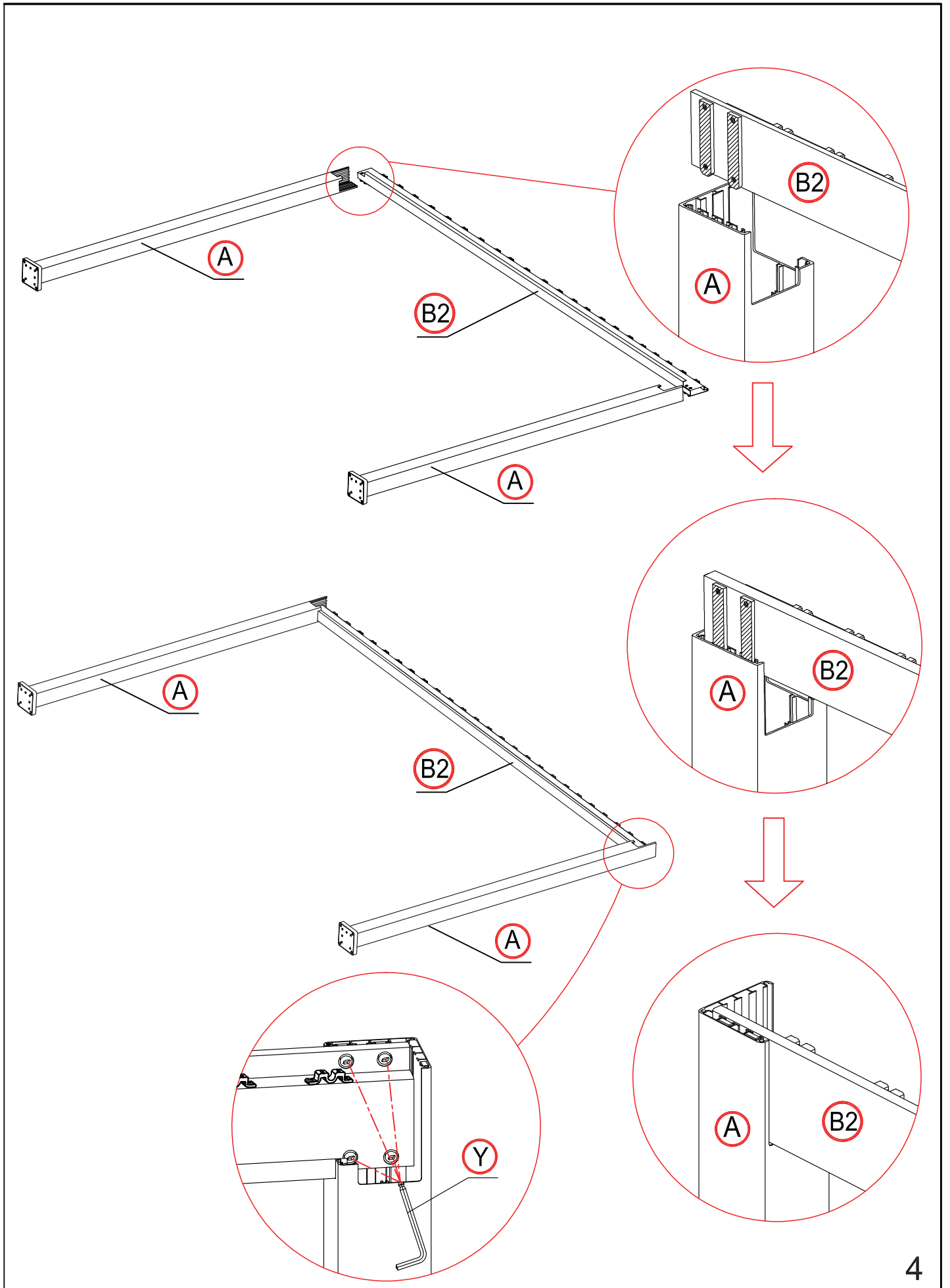

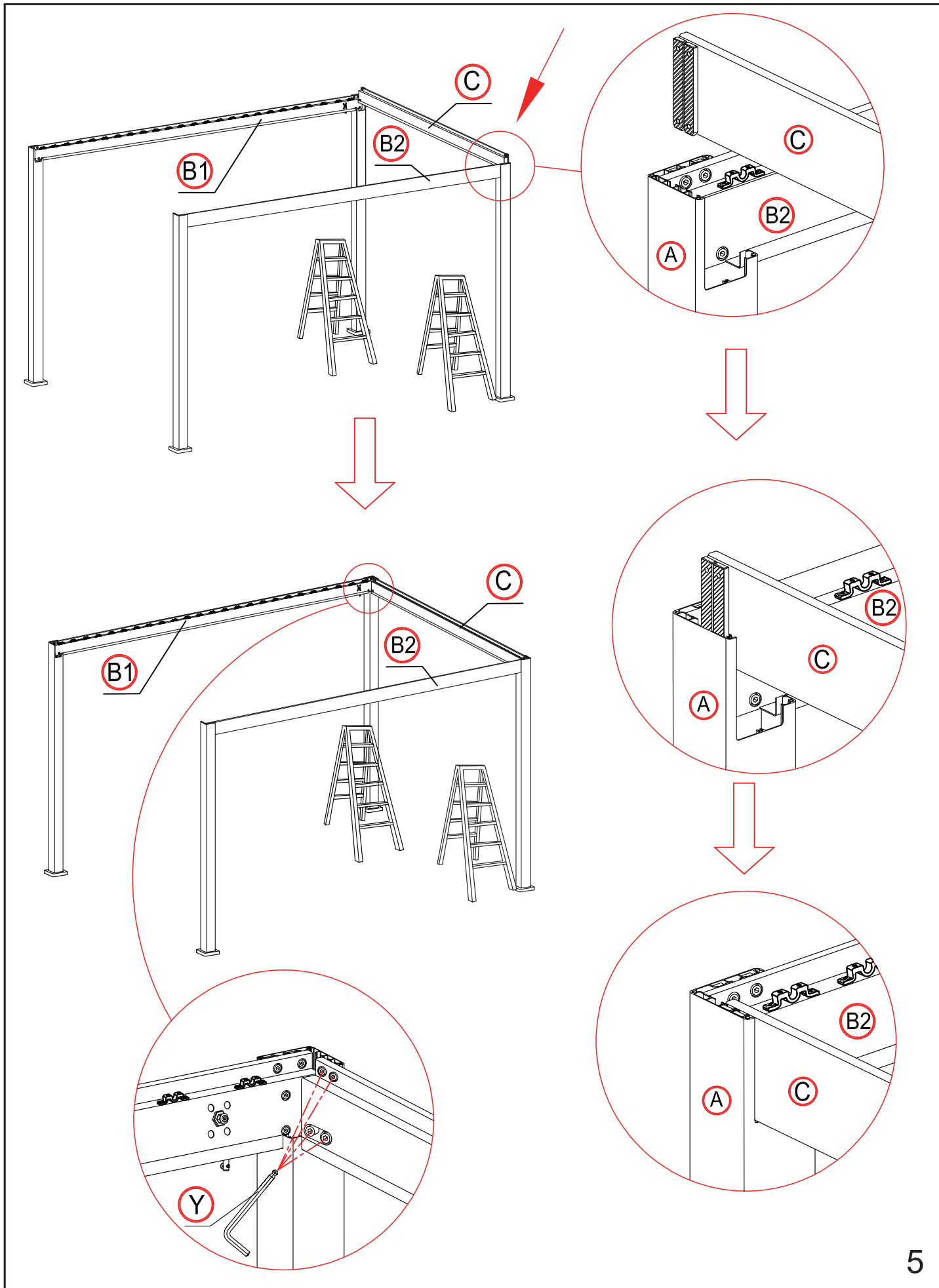

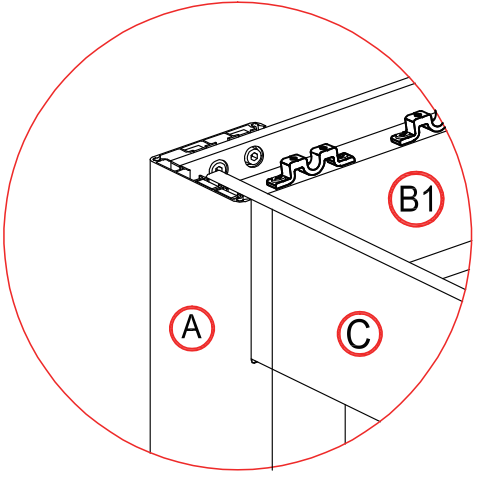
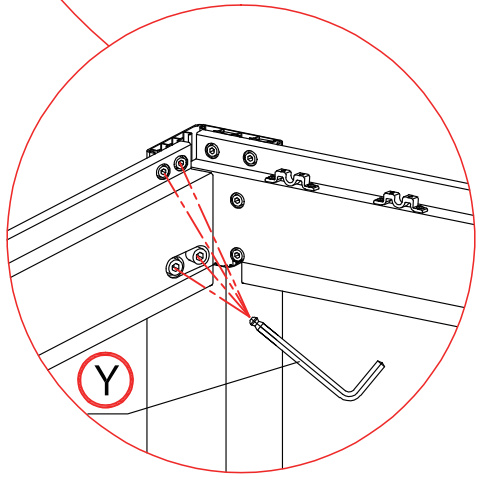
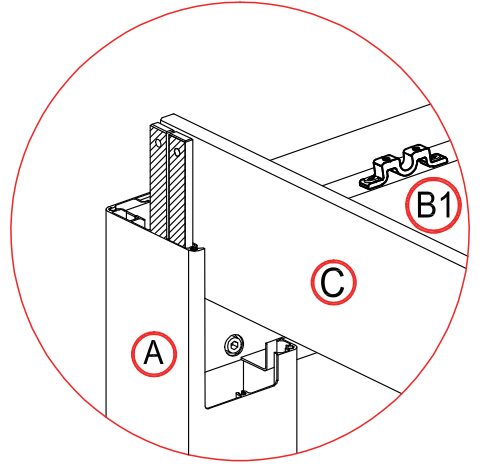
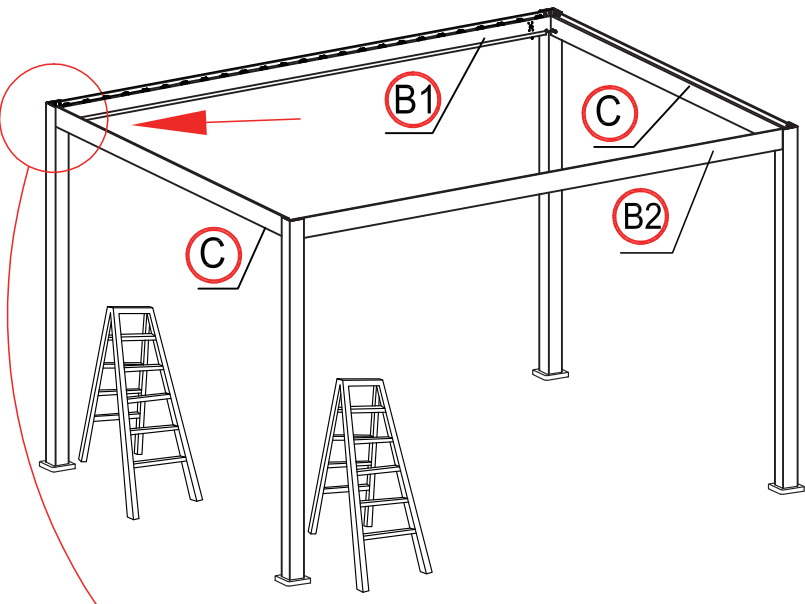
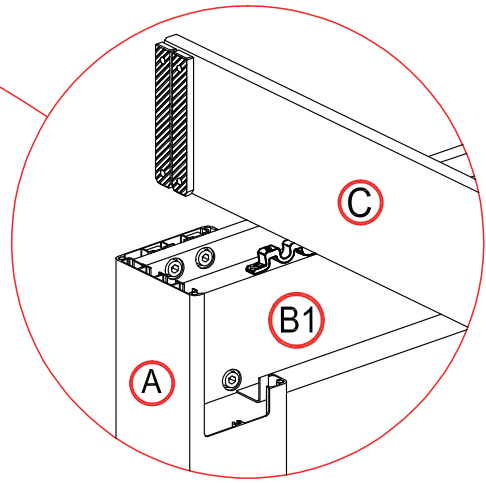
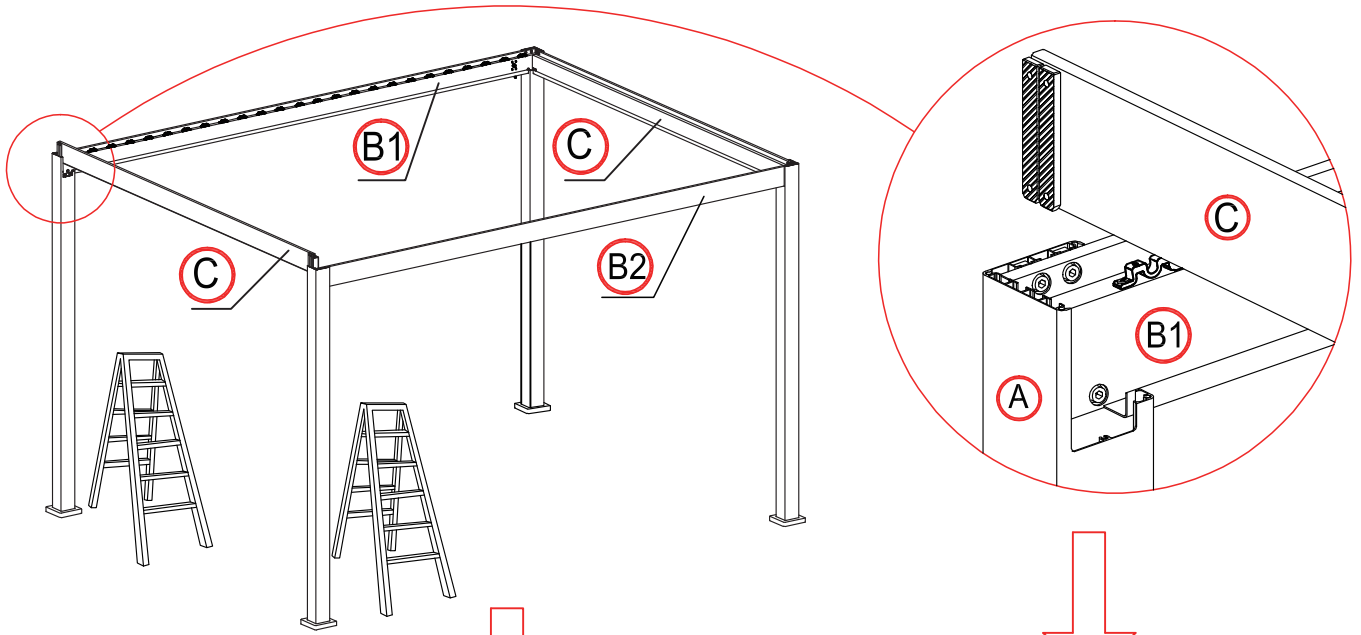

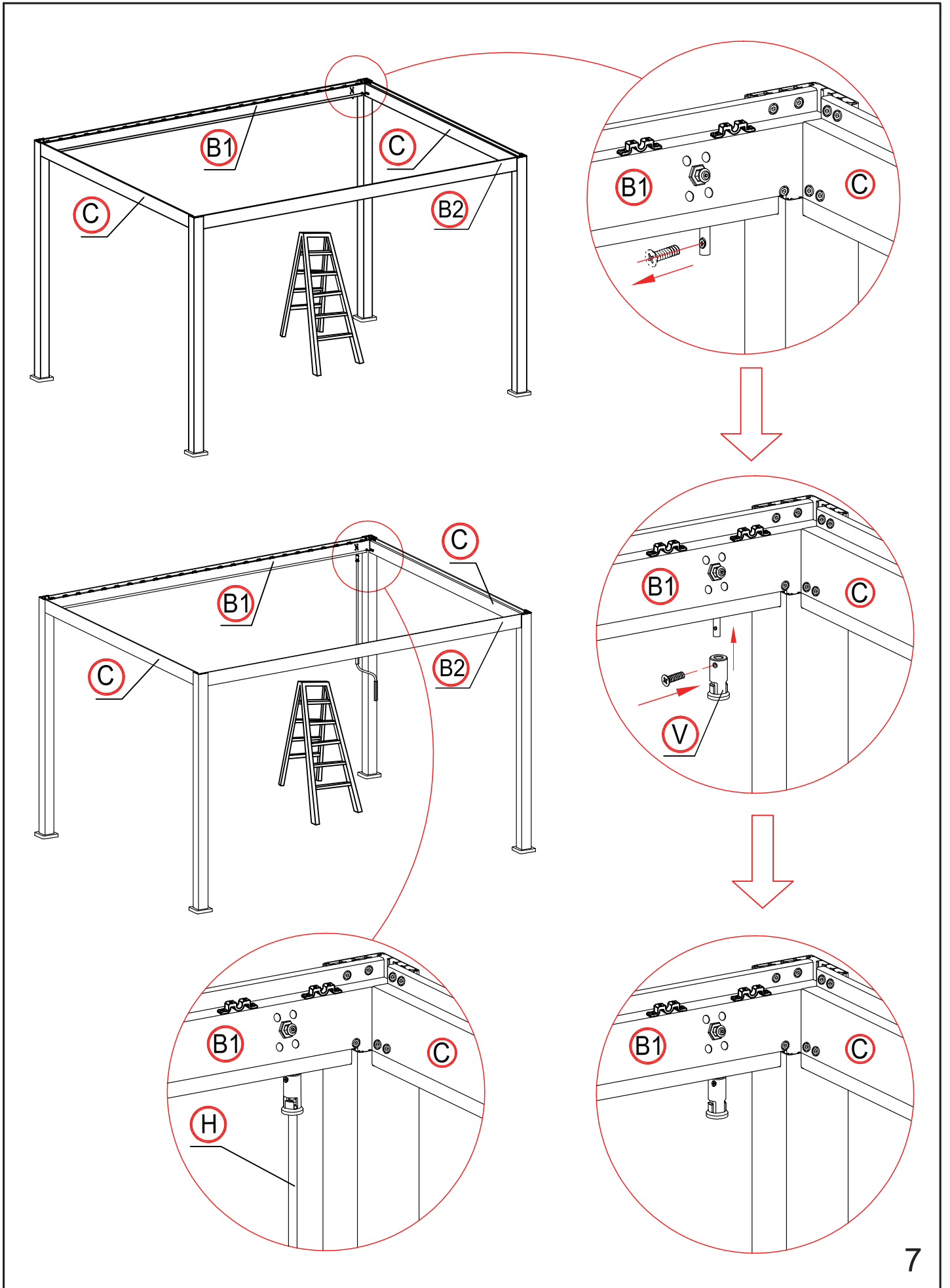

×1 time

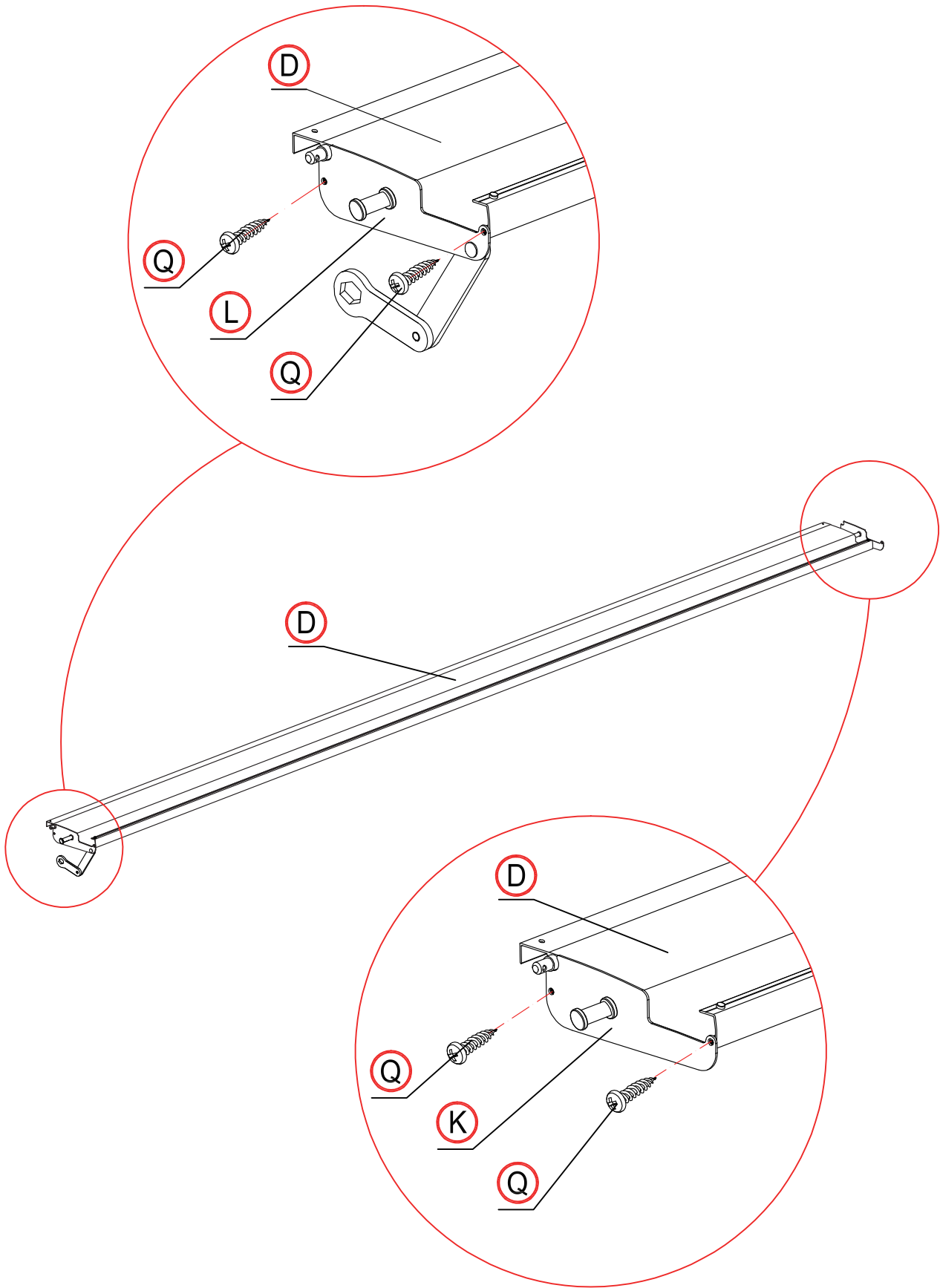

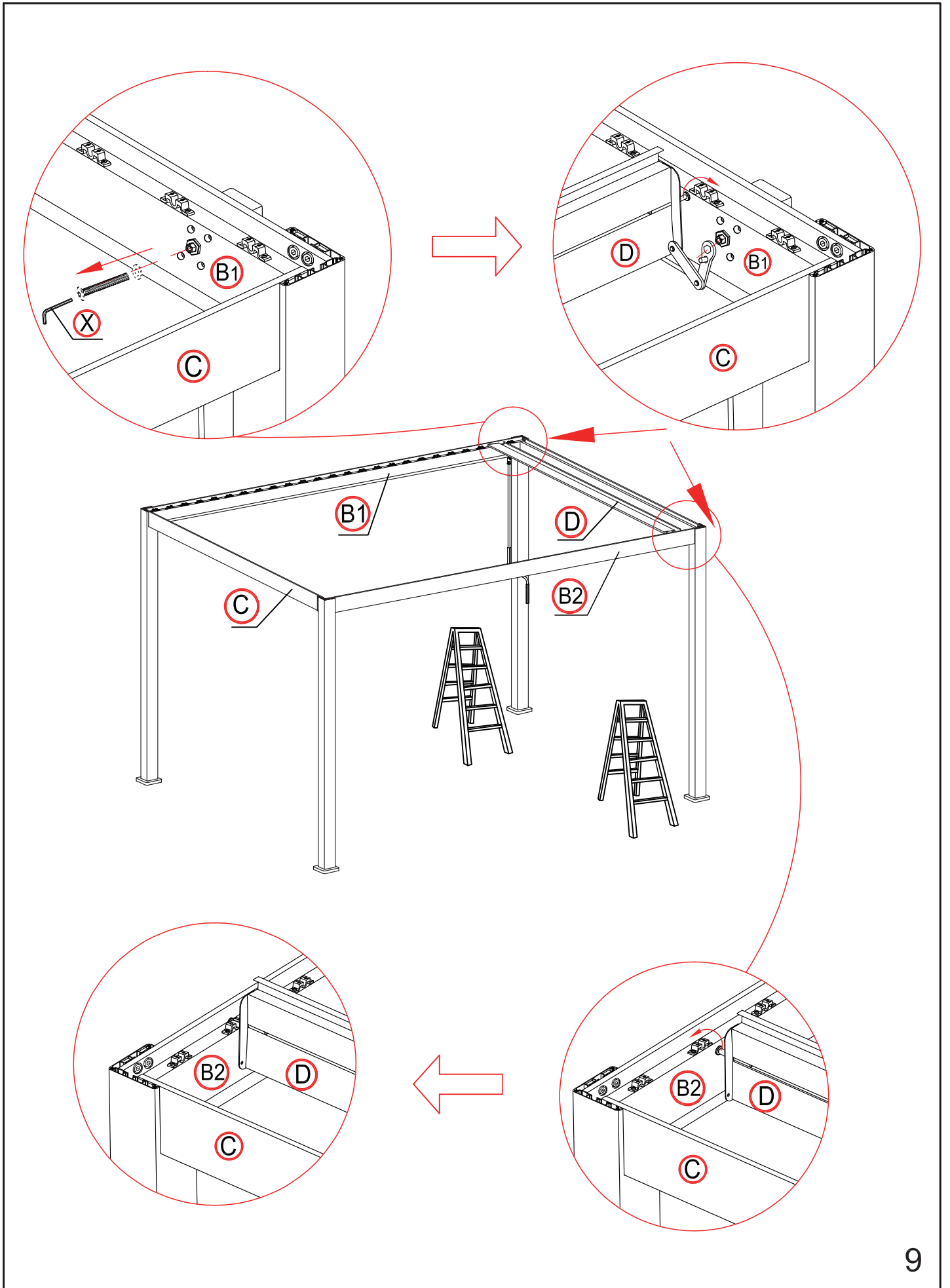

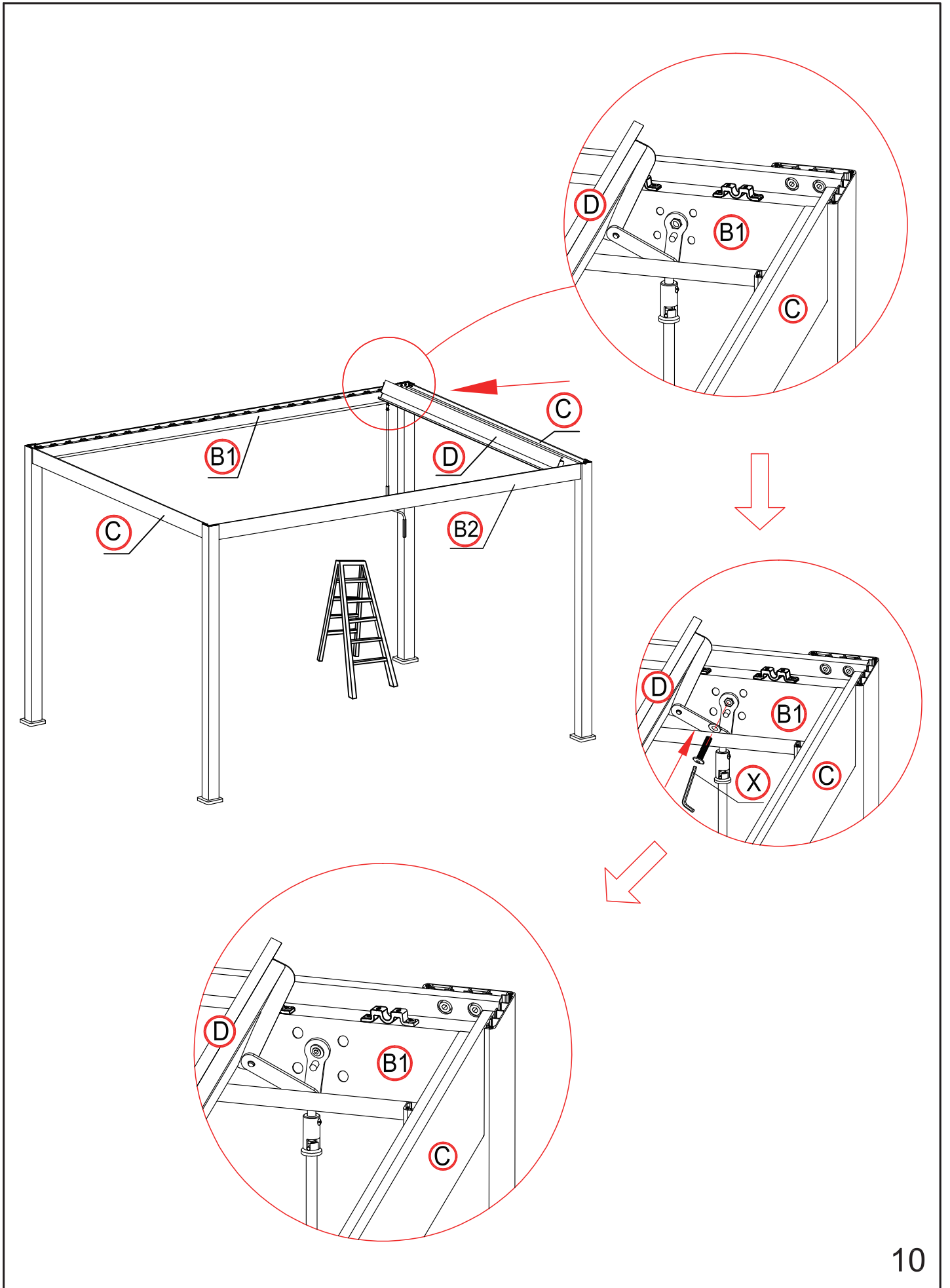

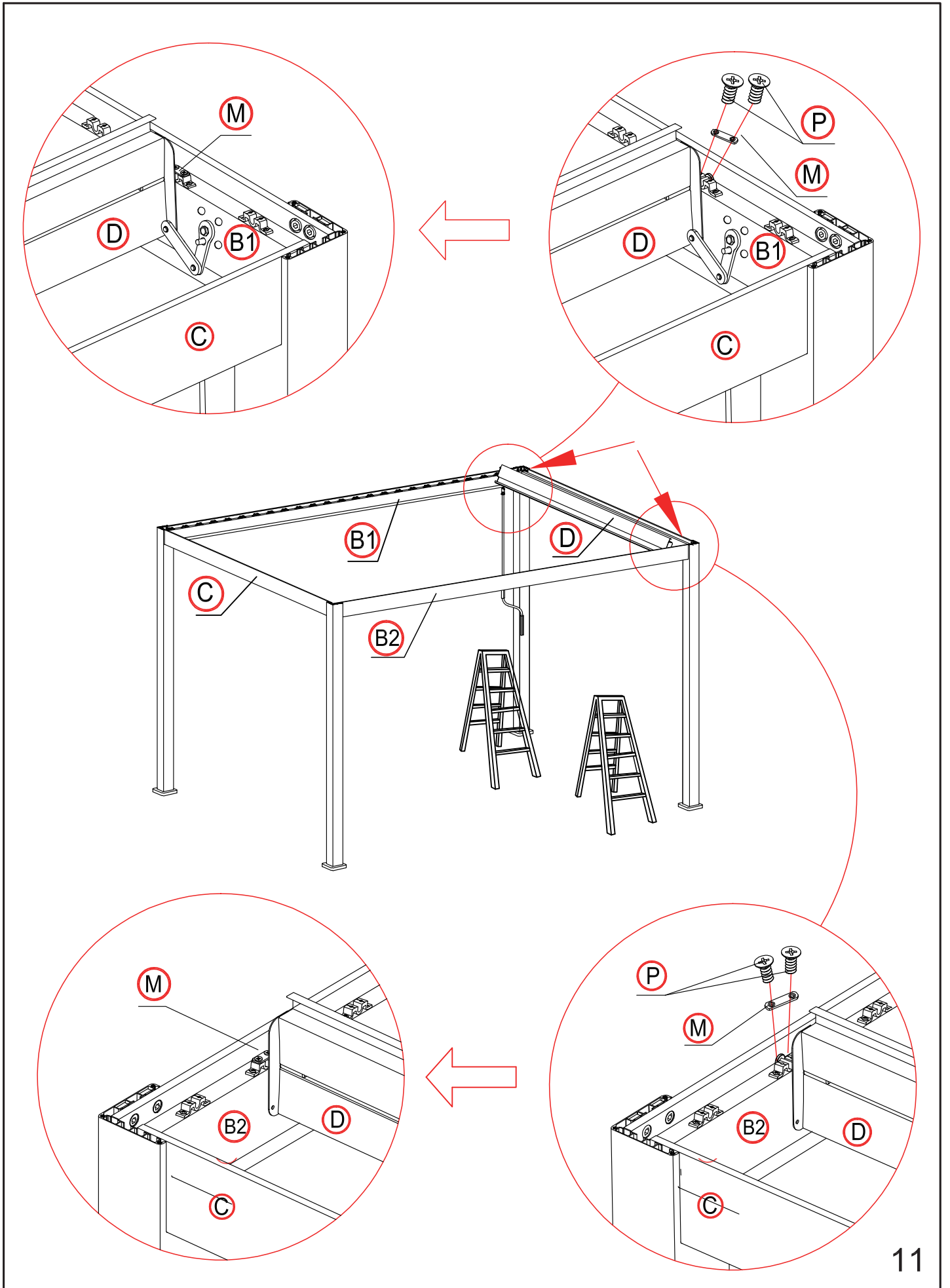

×24 times

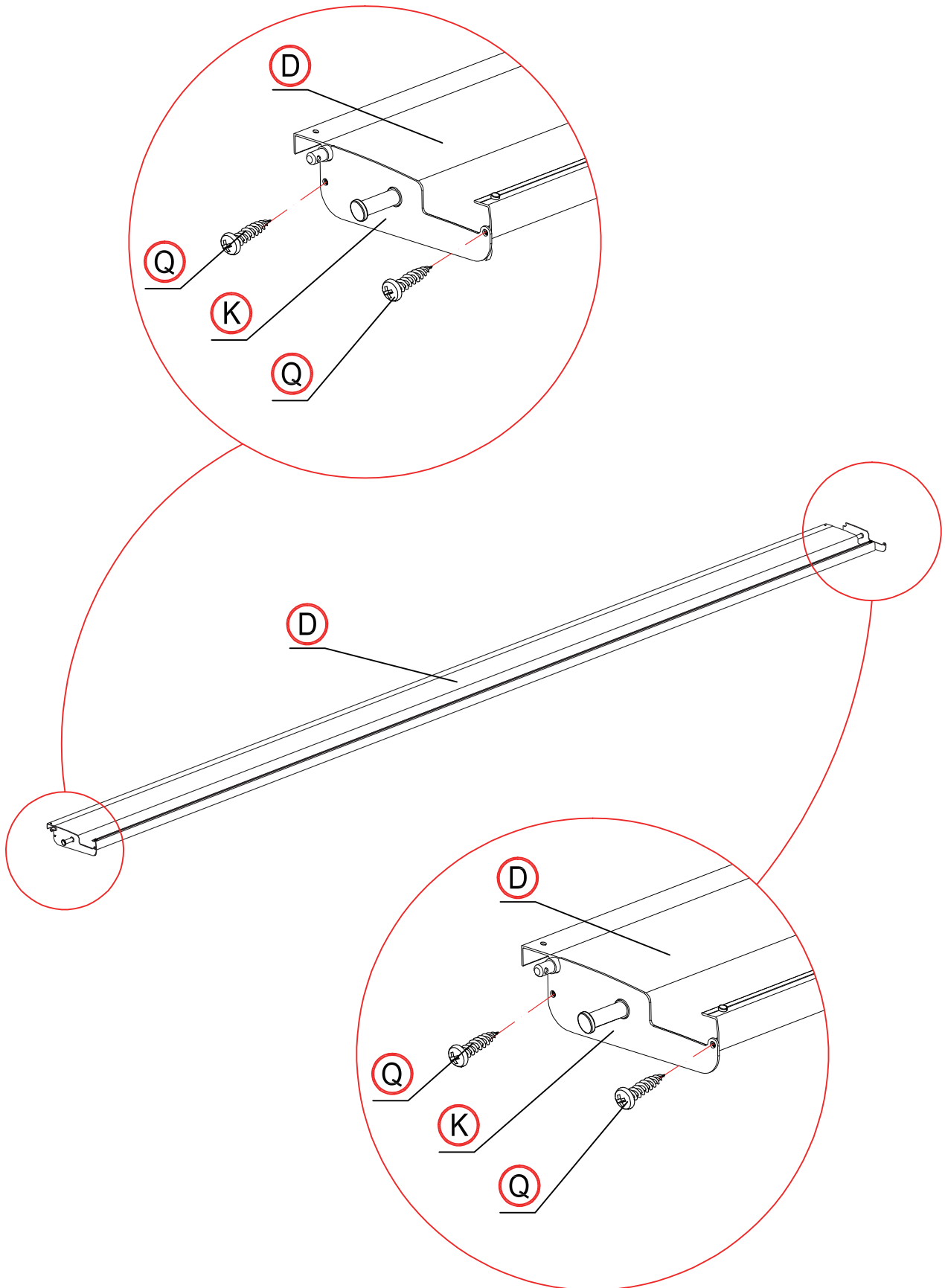

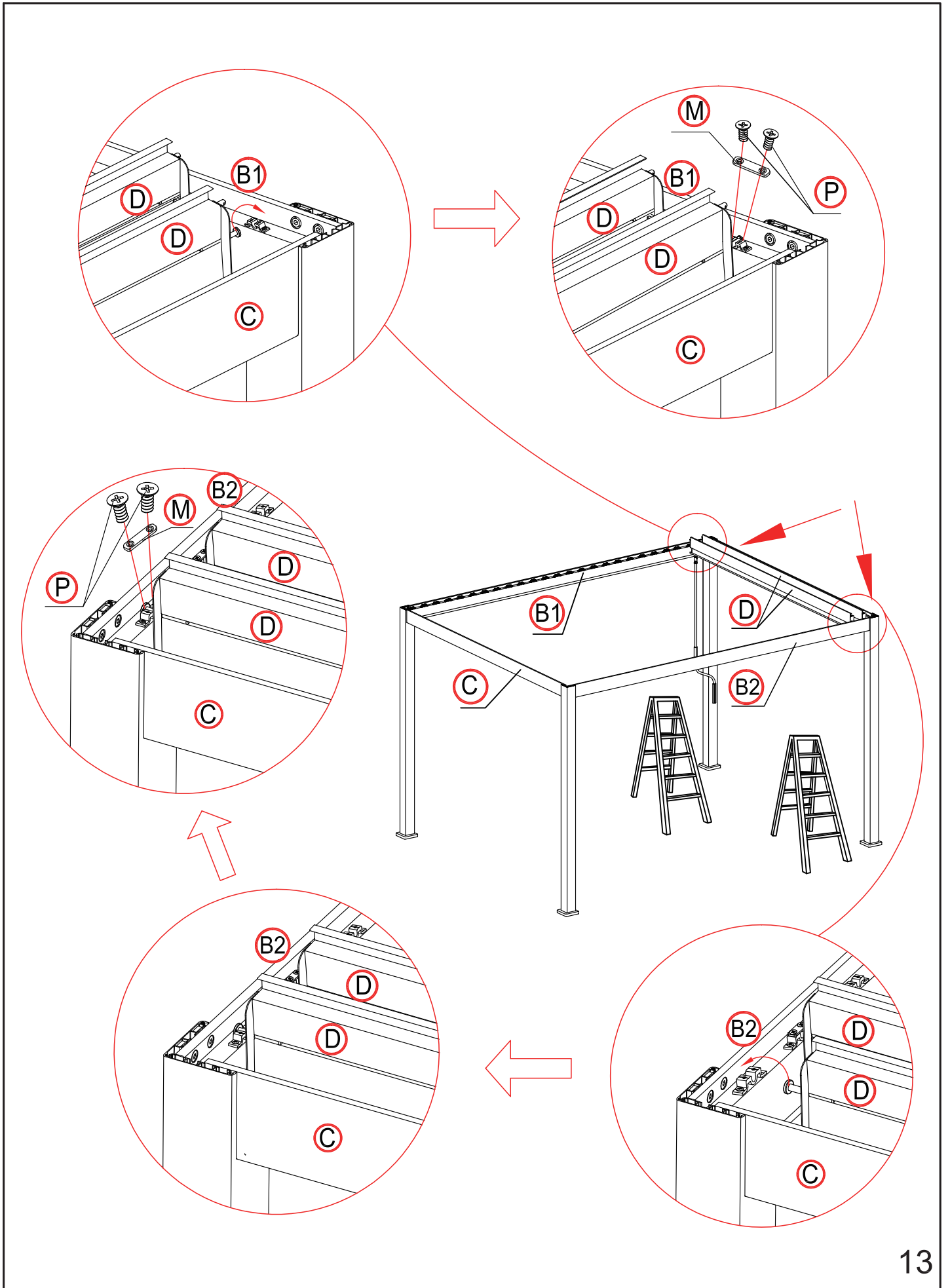

- IT** USARE LA MANOVELLA PER ALZARE LA SECONDA LAMELLA (POSIZIONE VERTICALE)
- EN** USE CRANK TO OPEN THE SECOND LAMELLAR BAR (VERTICAL POSITION)
- FR** UTILISEZ LA MANIVELLE POUR ÉLEVER LA DEUXIÈME LAMELLE (POSITION VERTICALE)
- DE** VERWENDEN DIE KURBEL UM DIE ZWEITE LAMELLE AUFZURICHTEN (VERTIKALE POSITION)
- ES** UTILIZAR LA MANIVELA PARA LEVANTAR LA SEGUNDA LAMA (POSICIÓN VERTICAL)

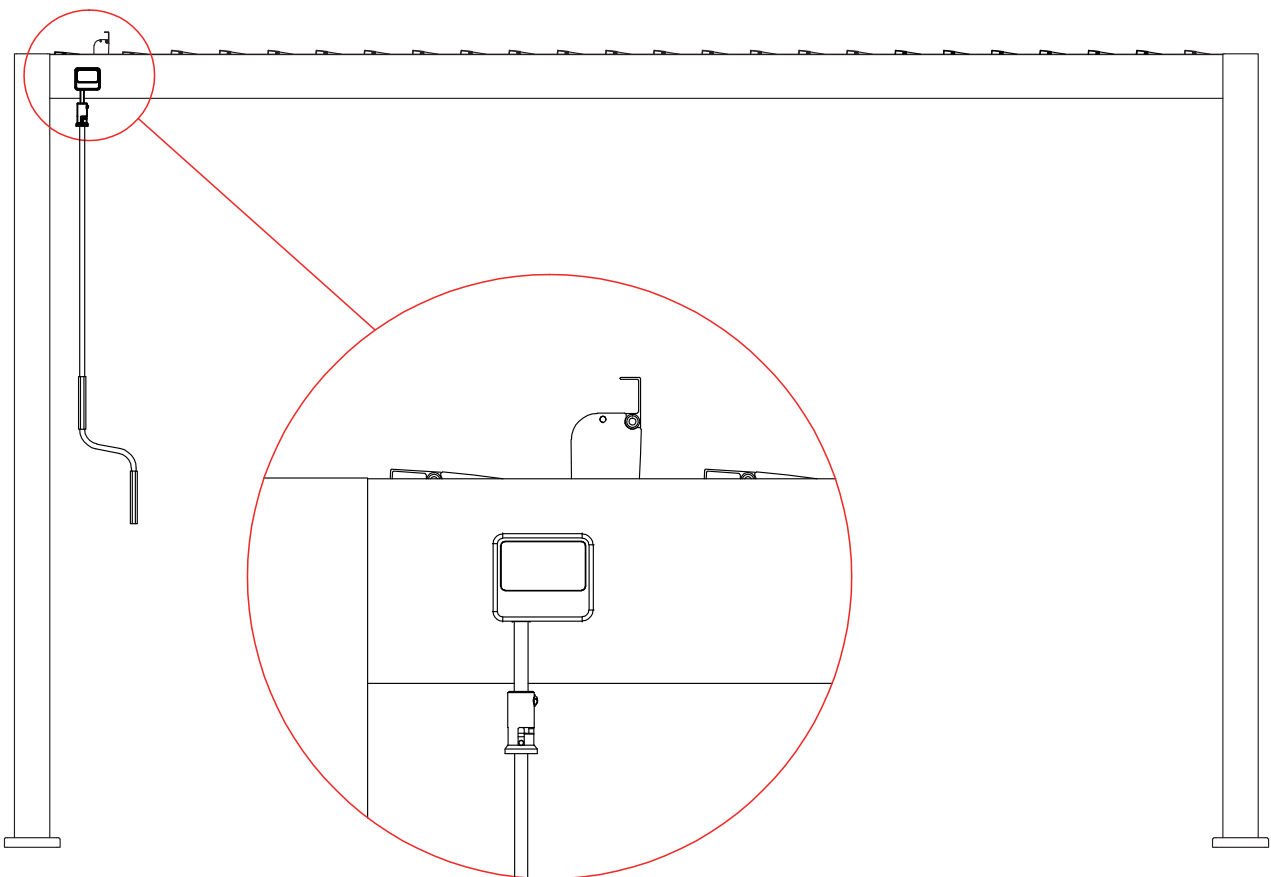

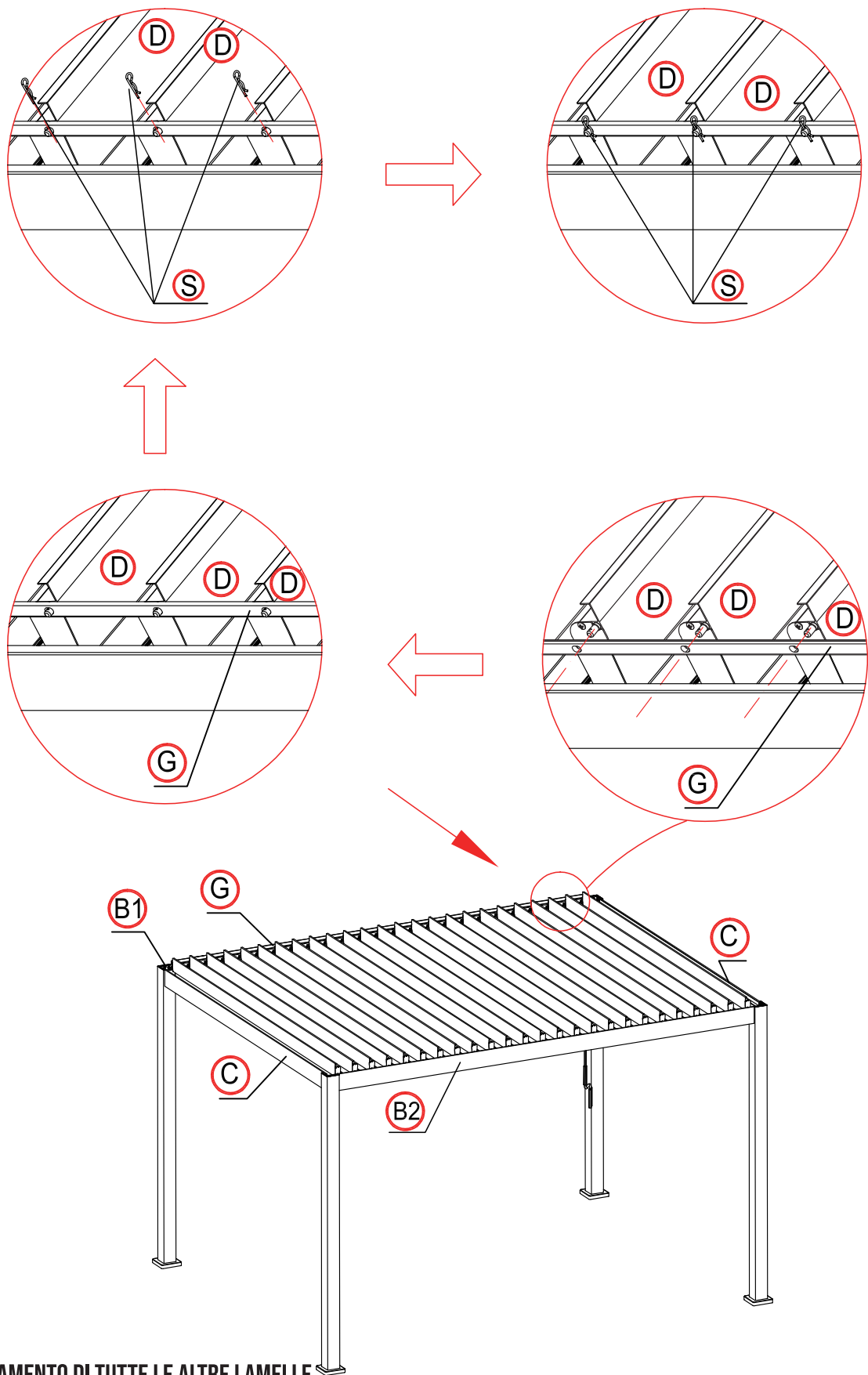

- IT** PROCEDERE AL COLLEGAMENTO DI TUTTE LE ALTRE LAMELLE
- EN** PROCEED TO JOINT ALL OTHER LAMELLAR SLATS
- FR** PROCÉDEZ À CONNECTER TOUTES LES AUTRES LAMELLES
- DE** ALLE ANDEREN LAMELLEN VERBINDEN
- ES** PROCEDER CONECTANDO TODAS LAS DEMÁS LAMAS

×4 times

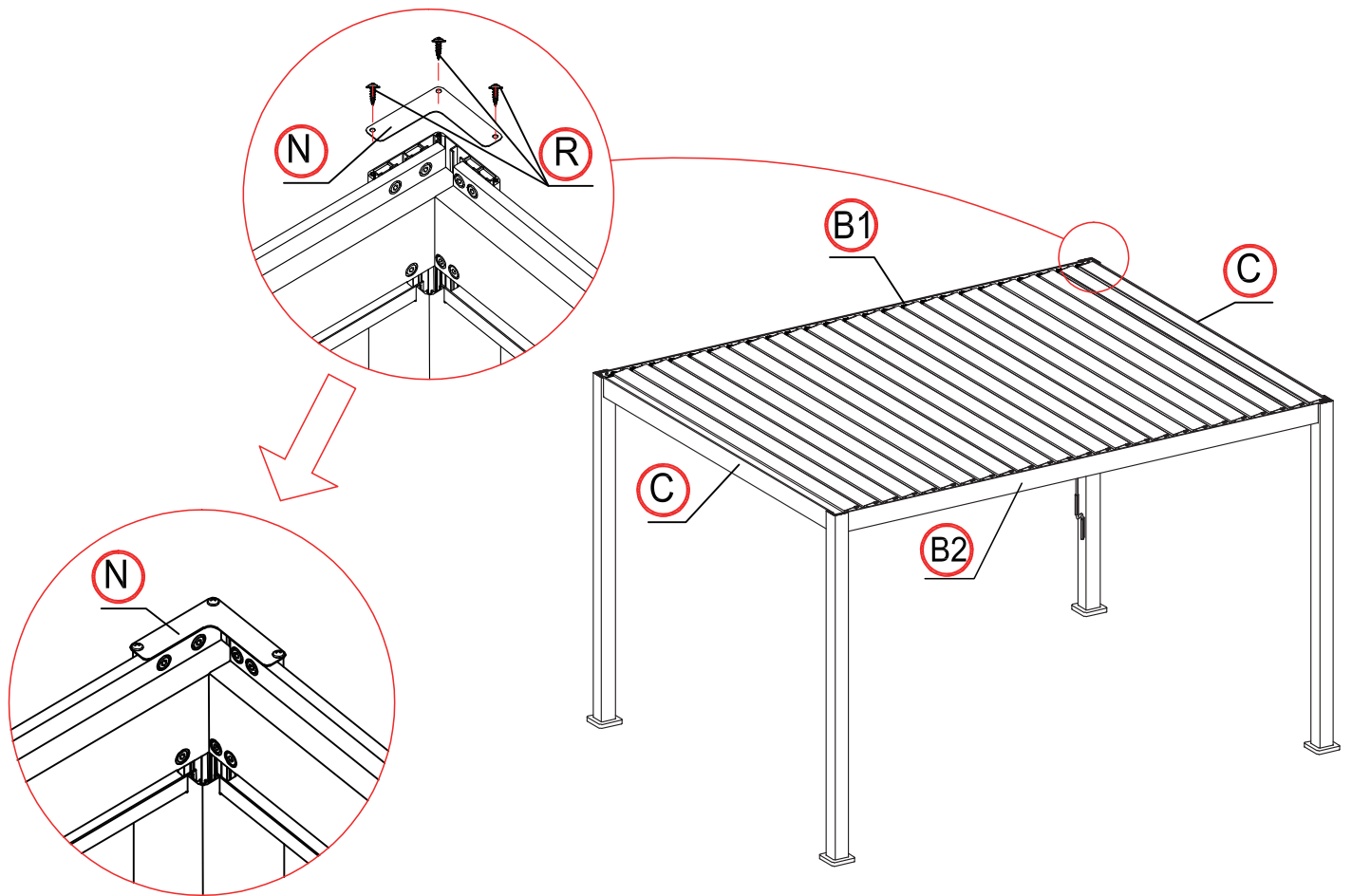

×4 times

IT

SI PREGA DI INSTALLARE LA PERGOLA SU UN SUOLO PIANO E SOLIDO.
PER EVITARE EVENTUALI PROBLEMI DURANTE L'INSTALLAZIONE DI ALTRI ACCESSORI IN FUTURO,
PER FAVORE, STRINGERE TUTTI I BULLONI DI ESPANSIONE DOPO AVER VERIFICATO CHE LA PERGOLA
SIA POSIZIONATA SIA ORIZZONTALMENTE CHE VERTICALMENTE IN MANIERA CORRETTA.
NELLA CONFEZIONE È INCLUSA UNA PUNTA PER TRAPANO A PERCUSSIONE SDS-PLUS DA 12 MM DI DIAM. (PARTE "Z").
POTREBBE ESSERE NECESSARIO UTILIZZARE LA PROPRIA PUNTA SE QUELLA IN DOTAZIONE NON SI ADATTA AL VOSTRO TRAPANO.

EN

PLEASE, INSTALL THE PERGOLA ON FLAT AND FIRM GROUND.
TO AVOID ANY POSSIBLE ISSUES WHEN INSTALLING OTHER ACCESSORIES IN THE FUTURE,
PLEASE, TIGHTEN ALL EXPANSION BOLDS AFTER MAKING SURE HORIZONTAL AND VERTICAL DIMENSIONS ARE CORRECT.
A 12MM DIAMETER SDS-PLUS HAMMER DRILL BIT (PART "Z") IS INCLUDED IN THE PACKAGE.
YOU MAY HAVE TO USE YOUR OWN DRILL BIT IF IT DOES NOT FIT YOUR DRILL.

ES

INSTALE LA PÉRGOLA EN UN SUELO PLANO Y SÓLIDO.
PARA EVITAR PROBLEMAS AL INSTALAR OTROS ACCESORIOS EN EL FUTURO, POR FAVOR APRIETE TODOS LOS PERNOS DE EXPANSIÓN DESPUÉS DE
ASEGURARSE DE QUE LA PÉRGOLA ESTÉ COLOCADA CORRECTAMENTE TANTO HORIZONTAL COMO VERTICALMENTE.
EN EL PAQUETE SE INCLUYE UNA BROCA PARA TALADRO PERCUTOR SDS-PLUS DE 12 MM DE DIÁMETRO. (PARTE "Z").
ES POSIBLE QUE DEBA USAR SU PROPIA BROCA SI LA EN DOTACIÓN NO SE AJUSTA A SU TALADRO

FR

VEUILLEZ INSTALLER LA TONNELLE SUR UN TERRAIN PLAT ET FERME.
POUR ÉVITER TOUT PROBLÈME ÉVENTUEL LORS DE L'INSTALLATION D'AUTRES ACCESSOIRES À L'AVENIR,
S'IL VOUS PLAÎT, SERREZ TOUS LES BOULONS D'EXPANSION APRÈS AVOIR VÉRIFIÉ QUE LES DIMENSIONS HORIZONTALES ET VERTICALES SONT CORRECTES.
UNE POINTE POUR PERCEUSE SDS-PLUS DE 12 MM DE DIAMÈTRE (PIÈCE « Z ») EST INCLUS DANS L'EMBALLAGE.
VOUS DEVREZ PEUT-ÊTRE UTILISER VOTRE PROPRE POINTE SI CELLE FOURNIE NE CORRESPOND PAS À VOTRE PERCEUSE

DE

BITTE MONTIEREN SIE DIE PERGOLA AUF EBENEM UND FESTEM BODEN.
UM PROBLEME BEIM SPÄTEREN EINBAU VON ANDEREM ZUBEHÖR ZU VERMEIDEN, BITTE ZIEHEN SIE ALLE DEHNSCHRAUBEN FEST,
NACHDEM SIE BESTÄTIGT HABEN, DASS DIE PERGOLA SOWOHL HORIZONTAL ALS AUCH VERTIKAL RICHTIG POSITIONIERT IST.
IN DER PACKUNG IST EINE SDS-PLUS-SPITZE (12 MM DURCHMESSER) FÜR SCHLAGBOHRMASCHINE INBEGRIFFEN. (TEIL „Z“)
MÖGLICHERWEISE MÜSSEN SIE IHRE SPITZE VERWENDEN, WENN DIE MITGELIEFERTE NICHT ZU IHRER SCHLAGBOHRMASCHINE PASST.

