

IMPORTANTE - TENERE PER FUTURE CONSULTAZIONI: LEGGERE ATTENTAMENTE
IMPORTANT - RETAIN FOR FUTURE REFERENCE: READ CAREFULLY
IMPORTANTE - ARCHIVAR LAS INSTRUCCIONES PARA CONSULTARLAS MÁS TARDE: LEA ATENTAMENTE
IMPORTANT - A CONSERVER POUR CONSULTATION ULTERIEURE: LIRE ATTENTIVEMENT
WICHTIG - FÜR ZUKUNFT REFERENZ AUFBEWAHREN: BITTE ES SORGFÄLTIG ZU LESEN



60 minutes



IT

PRIMA DI PROCEDERE CON IL MONTAGGIO, ASSICURARSI DI POSIZIONARE IL PRODOTTO SU UNA SUPERFICIE PIANA E PULITA E UTILIZZARE UN TELO MORBIDO D'APPOGGIO DURANTE L'ASSEMBLAGGIO. QUESTO PER EVITARE URTI E DANNI AL PRODOTTO DURANTE IL MONTAGGIO. NON STRINGERE LE VITI FINCHÉ NON SONO NELLA POSIZIONE CORRETTA.

EN

BEFORE PROCEEDING WITH THE ASSEMBLY, MAKE SURE TO PLACE THE PRODUCT ON A FLAT AND CLEAN SURFACE AND USE A SOFT COVER DURING ASSEMBLY TO AVOID IMPACTS AND DAMAGE TO THE PRODUCT. DON'T TIGHTEN THE SCREWS UNTIL ALL OF THEM ARE IN THE RIGHT POSITION.

ES

ANTES DEL MONTAJE, ASEGÚRESE DE COLOCAR EL PRODUCTO SOBRE UNA SUPERFICIE LIMPIA Y PLANA Y USE UNA TELA SUAVE COMO SOPORTE PARA EVITAR GOLPES Y DAÑOS AL PRODUCTO DURANTE EL MONTAJE. NO APRIETE LOS TORNILLOS HASTA QUE SE ENCUENTREN EN LA POSICIÓN CORRECTA.

FR

AVANT DE PROCÉDER À L'ASSEMBLAGE, ASSUREZ-VOUS DE PLACER LE PRODUIT SUR UNE SURFACE PLANE ET PROPRE ET D'UTILISER UN TISSU SOUPLE DE SUPPORT POUR ÉVITER DES COUPS ET DES DOMMAGES AU PRODUIT PENDANT L'ASSEMBLAGE. NE SERREZ PAS LES VIS JUSQU'À CE QU'ELLES SOIENT TOUTES DANS LA POSITION CORRECTE.





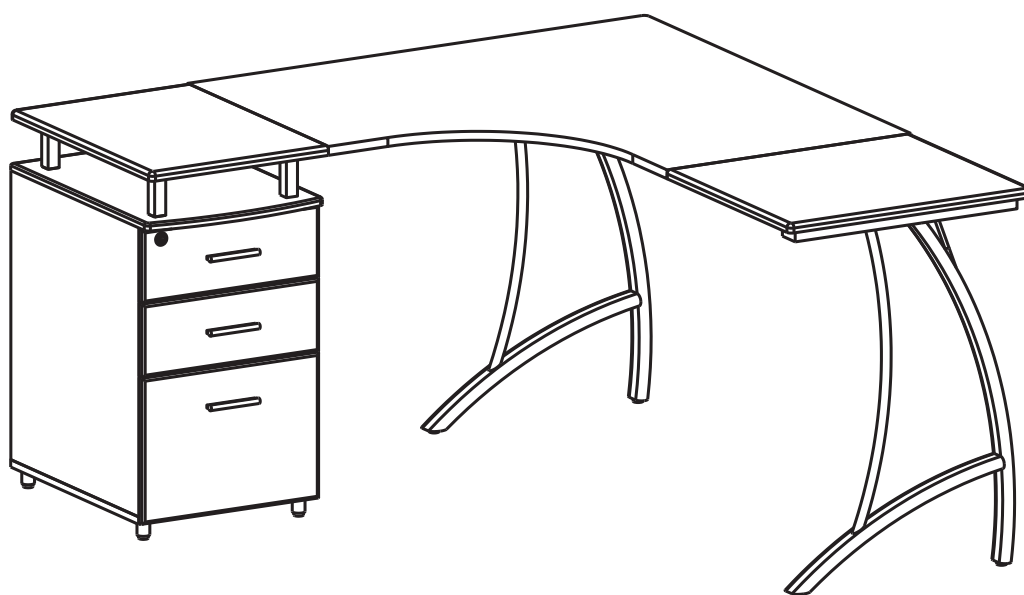

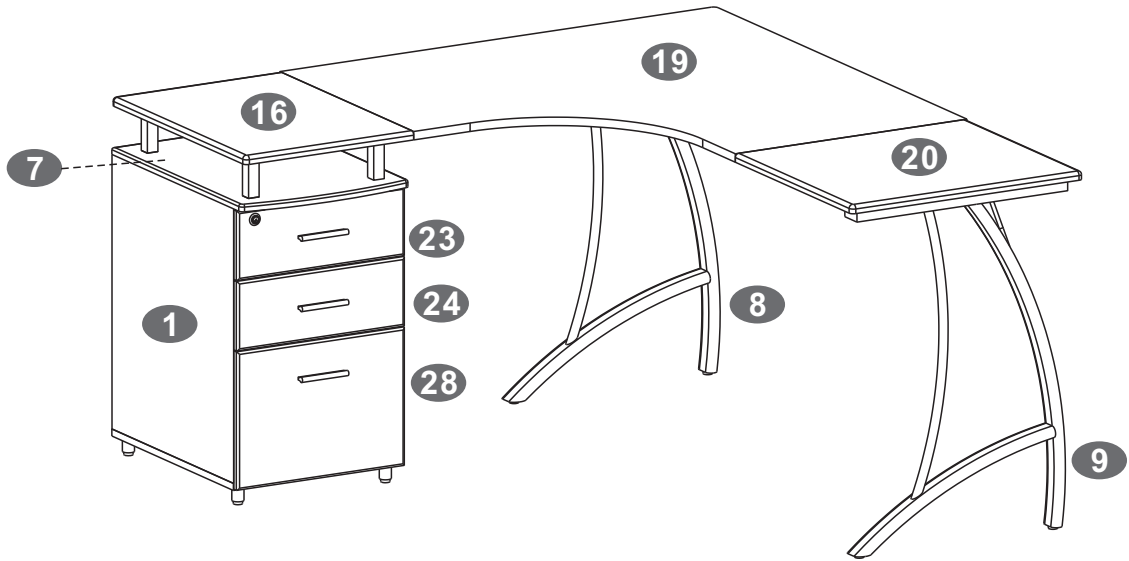

DE

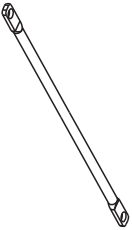
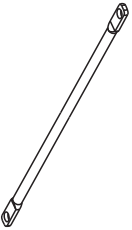
VOR DEM AUFBAU BITTE DAS PRODUKT AUF EINE EBENE UND SAUBERE FLÄCHE STELLEN UND ES EMPFIEHLT SICH, DAS PRODUKT AUF EINE WEICHE DECKE AUFZUBAUEN. SO WIRD VERHINDERT, DASS BEIM AUFBAU BESCHÄDIGUNGEN UND BEULEN AM PRODUKT ENTSTEHEN. SOLANGE ALLE SCHRAUBEN NICHT IN DER RICHTIGEN POSITION SIND, NICHT ANZIEHEN.

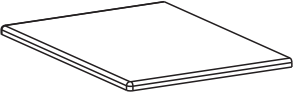

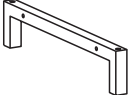
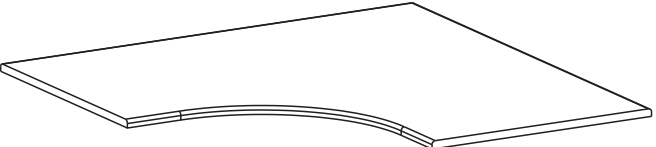

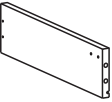
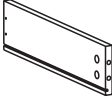
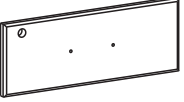
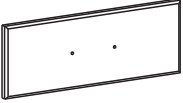
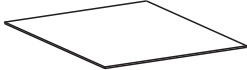

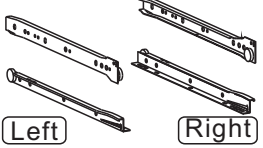
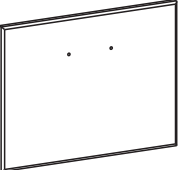
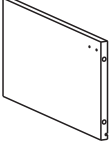
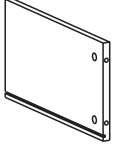
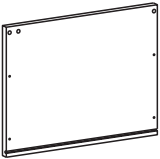

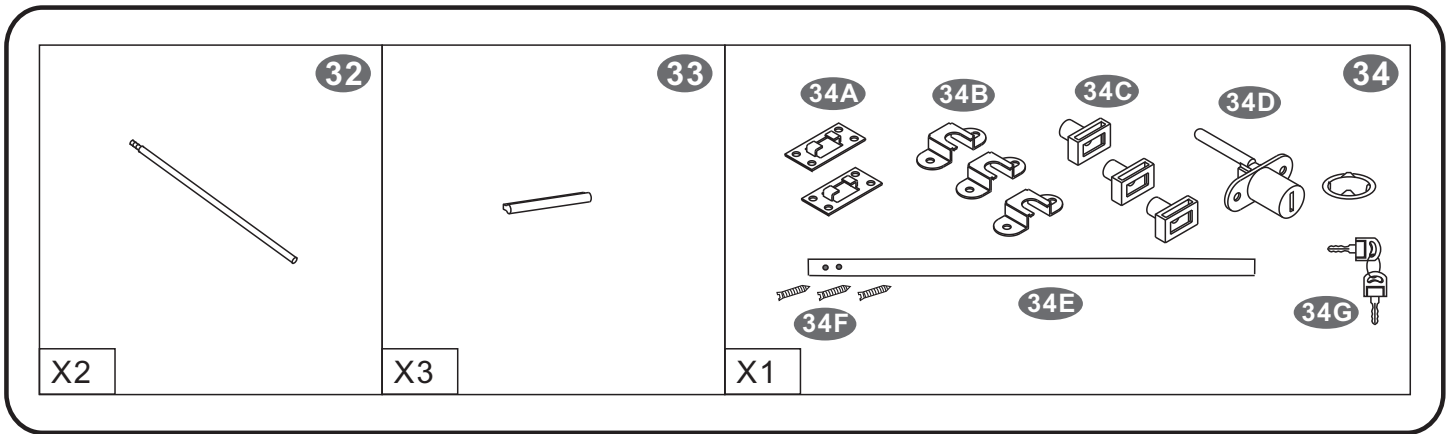



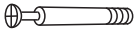

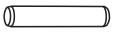
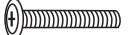
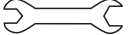
 X1	 X1	 X1	 X1
 X4	 X8	 X1	 X1
 X1	 X1	 X1	 X2

 <p>13</p> <p>X1</p>	 <p>14</p> <p>X1</p>	 <p>15</p> <p>X2</p>	 <p>16</p> <p>X1</p>
 <p>17</p> <p>X2</p>	 <p>18</p> <p>X1</p>	 <p>19</p> <p>X1</p>	
 <p>20</p> <p>X1</p>	 <p>21</p> <p>X2</p>	 <p>22</p> <p>X2</p>	 <p>23</p> <p>X1</p>
 <p>24</p> <p>X1</p>	 <p>25</p> <p>X3</p>	 <p>26</p> <p>X2</p>	 <p>27</p> <p>Left Right</p> <p>X3</p>
 <p>28</p> <p>X1</p>	 <p>29</p> <p>X1</p>	 <p>30</p> <p>X1</p>	 <p>31</p> <p>X1</p>

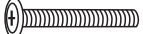

PART	QTY.	ITEM		PART	QTY.	ITEM	
A	40	3X15 MM		J	6	M6	
B	28	6X40 MM		K	28	Φ 15 MM	
C	4	6X25 MM		L	8	8X30 MM	
D	20	6X35 MM			1		
E	18	6X12 MM			1		
F	4	6X115 MM			1		
G	4	6X40 MM					
H	12	4X35 MM					
I	6	4X20 MM					

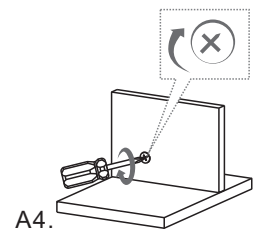
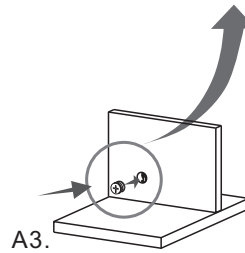
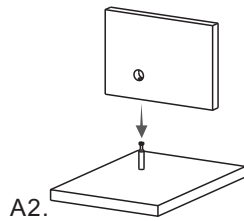
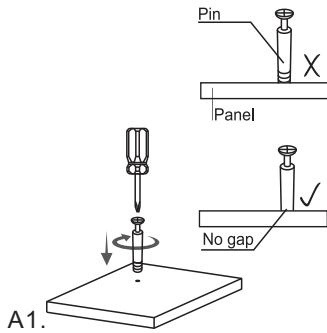
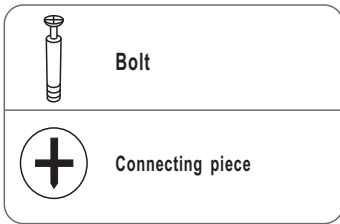

1

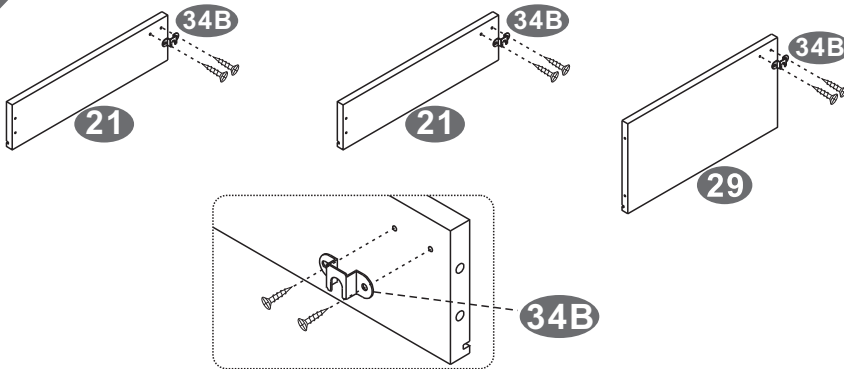

SCREWS

A 3X15 MM

X6



2

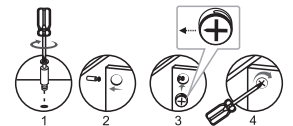
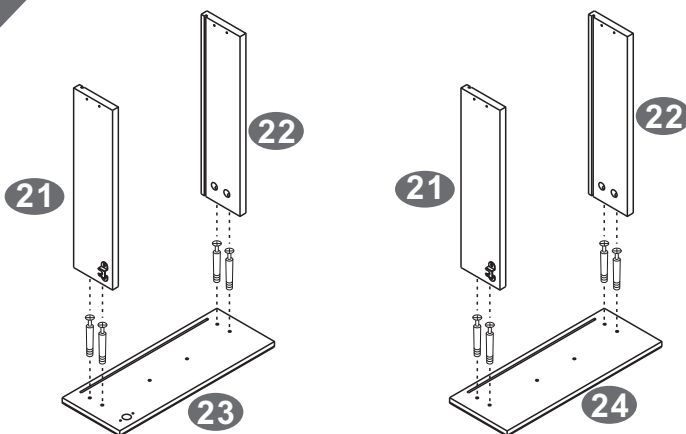

SCREWS

B 6X40 MM

X8

K Φ 15 MM

X8



3

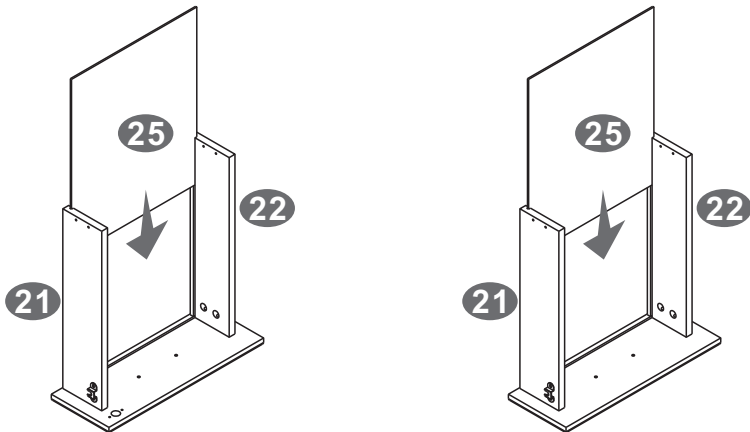

4

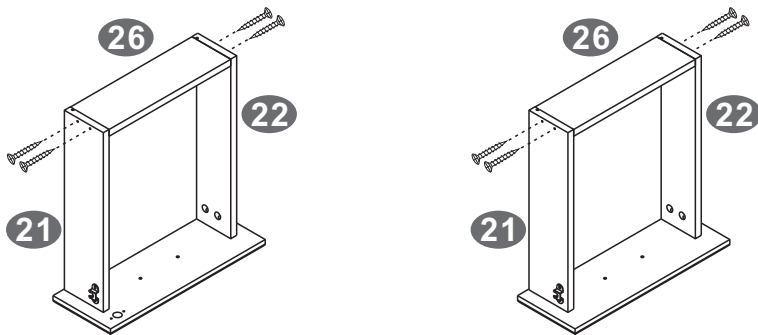

▪ SCREWS

H 4X35 MM

 X8



5

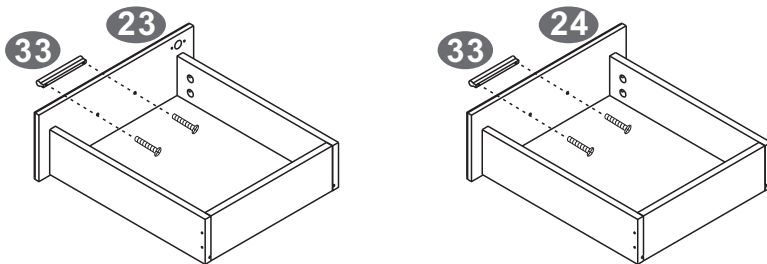

▪ SCREWS

I 4X20 MM

 X4



6

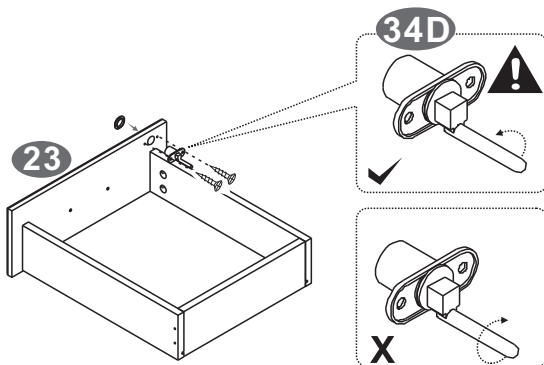

▪ SCREWS

A 3X15 MM



 X2

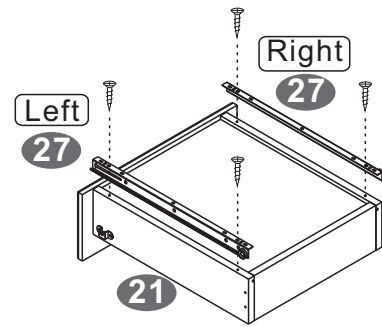
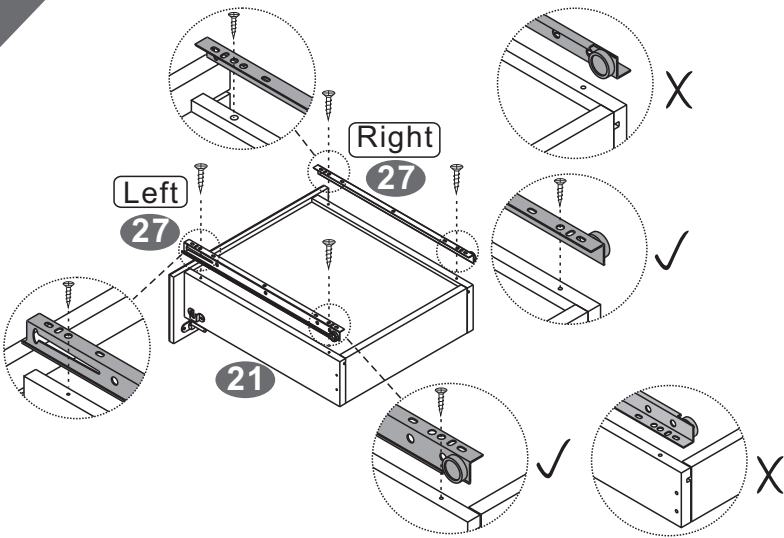

7





SCREWS

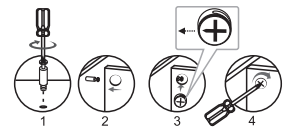
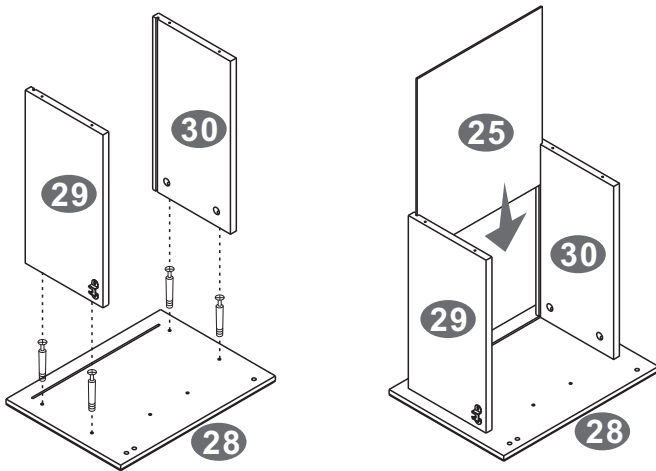

A 3X15 MM  X8 

8



SCREWS

B 6X40 MM  X4 

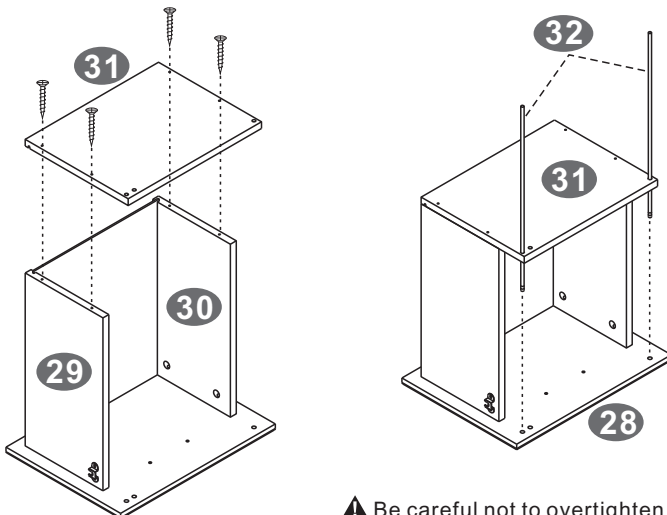

K Φ 15 MM  X4 

9



⚠ Be careful not to overtighten the metal rod

SCREWS

H 4X35 MM  X4 

10

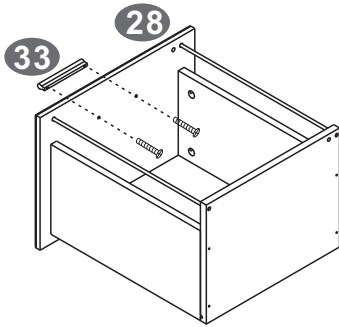

■ SCREWS

I 4X20 MM

X2



11

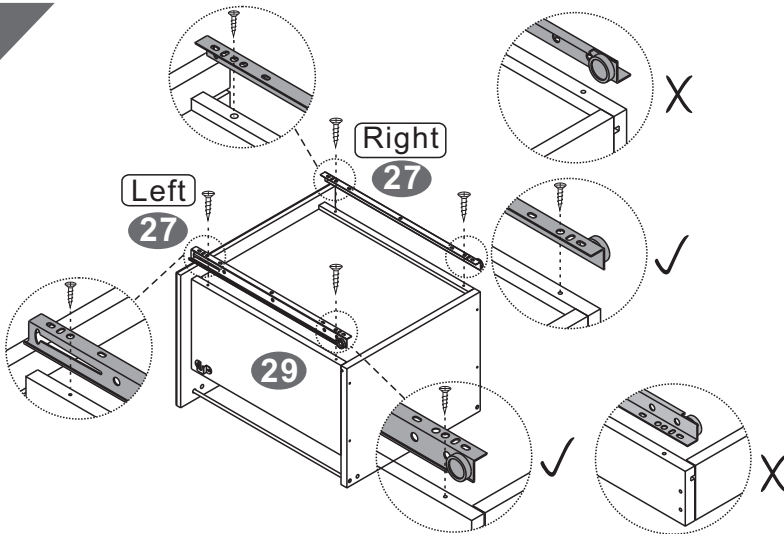

■ SCREWS

A 3X15 MM

X4



12

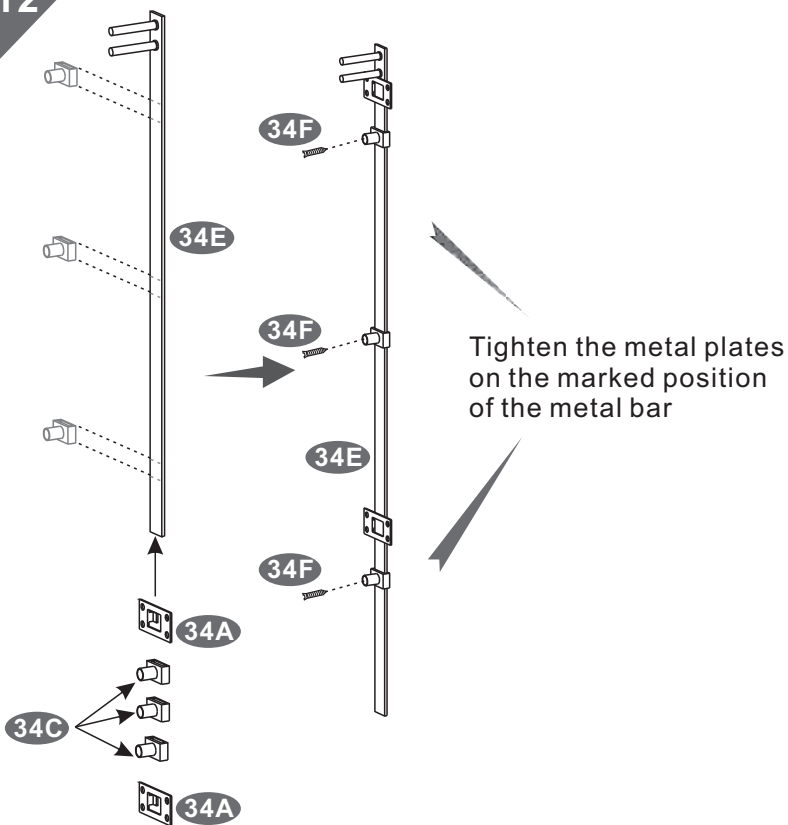

13

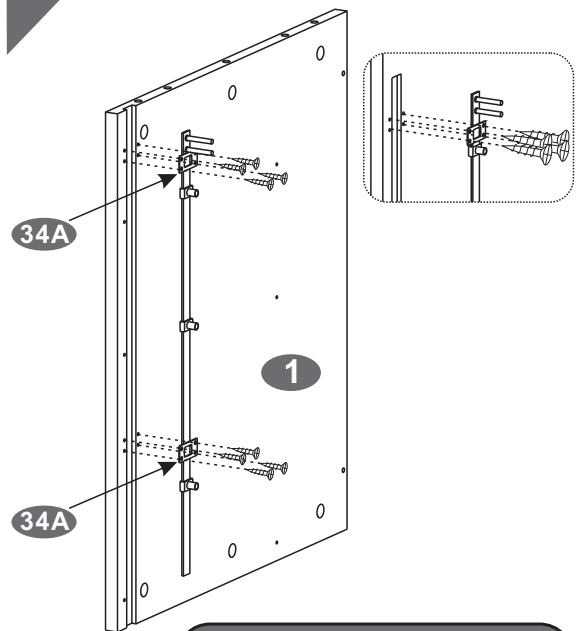

■ SCREWS

A 3X15 MM

X8



14

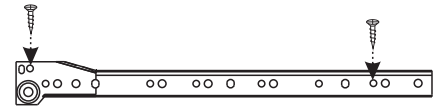
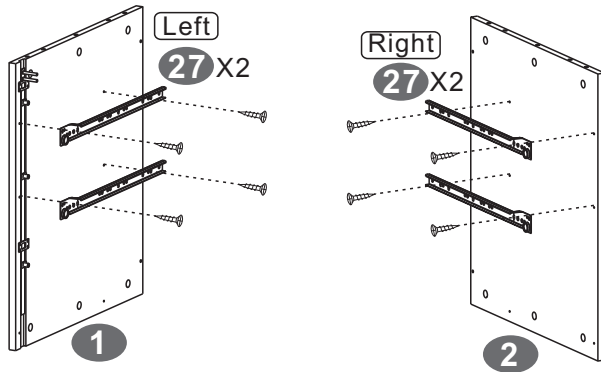

SCREWS

A 3X15 MM

X8



15

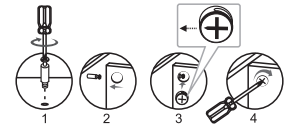
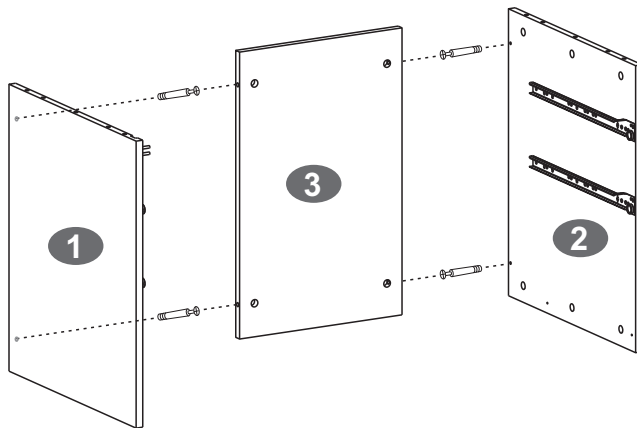

SCREWS

B 6X40 MM

X4



K Φ 15 MM

X4



16

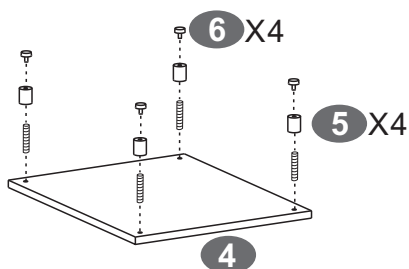

SCREWS

C 6X25 MM

X4

17

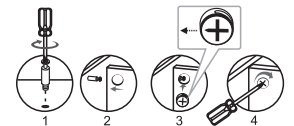
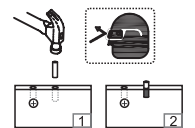
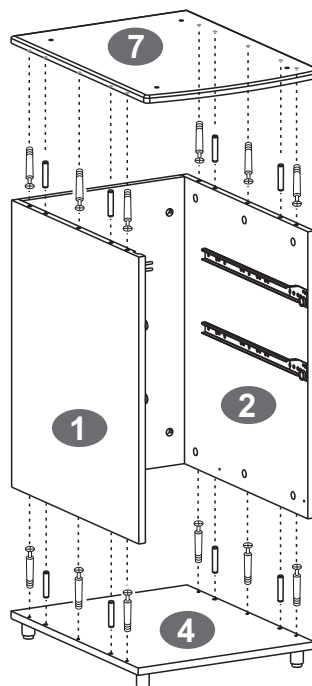

SCREWS

B 6X40 MM

X12



K Φ 15 MM

X12



L 8X30 MM

X8

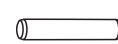

18

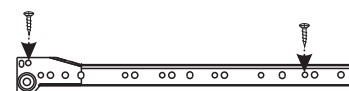
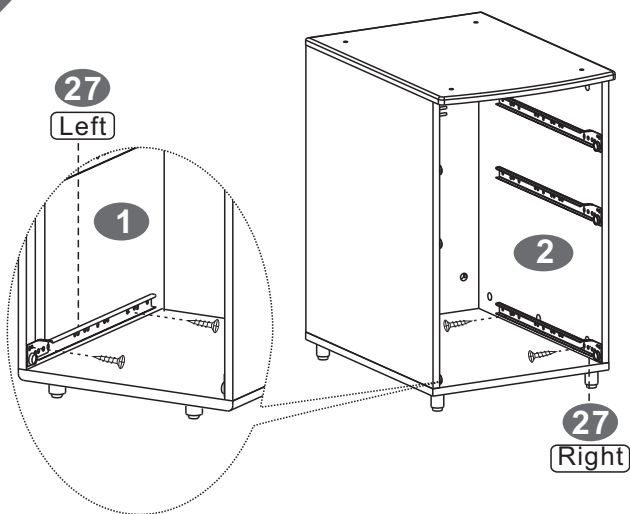

SCREWS

A 3X15 MM

X4

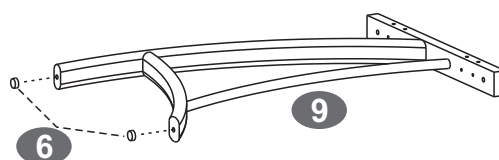
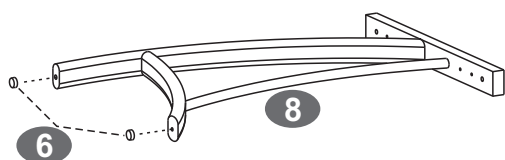

**** There are 2 options to assemble our desk, please choose it according to your preference.**

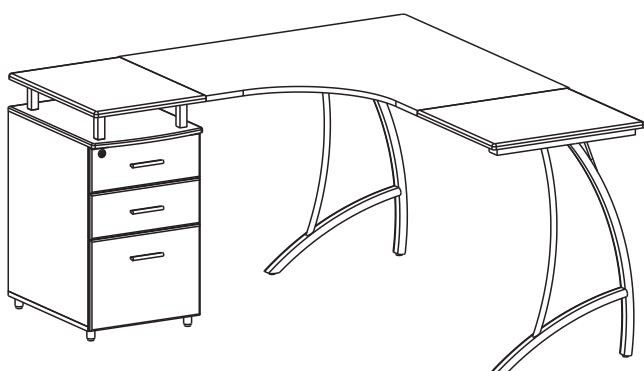

A

P11 A1 - A7

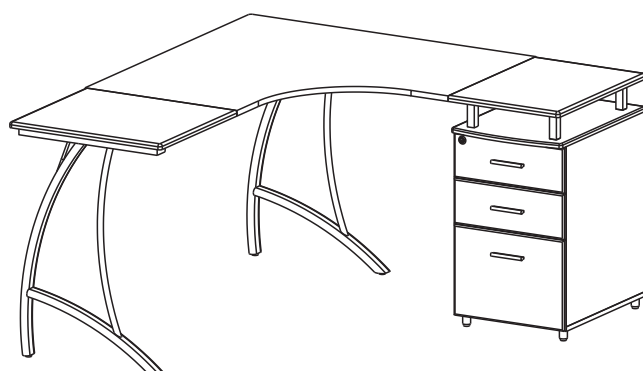

B

P14 B1 - B7

A1

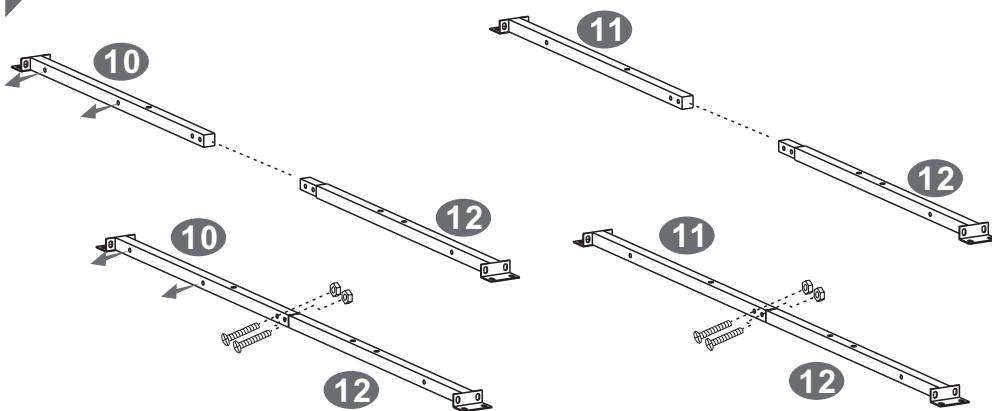

SCREWS

D 6X35 MM X4



J M6



X4



A2

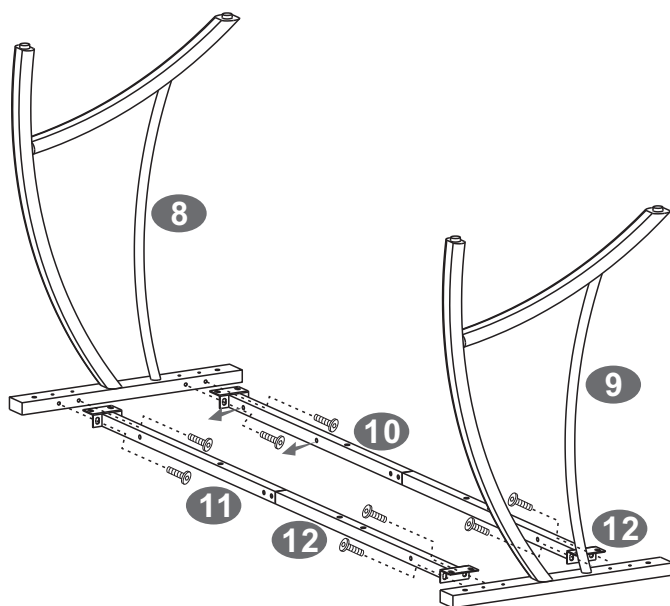

SCREWS

E 6X12 MM X8



A3

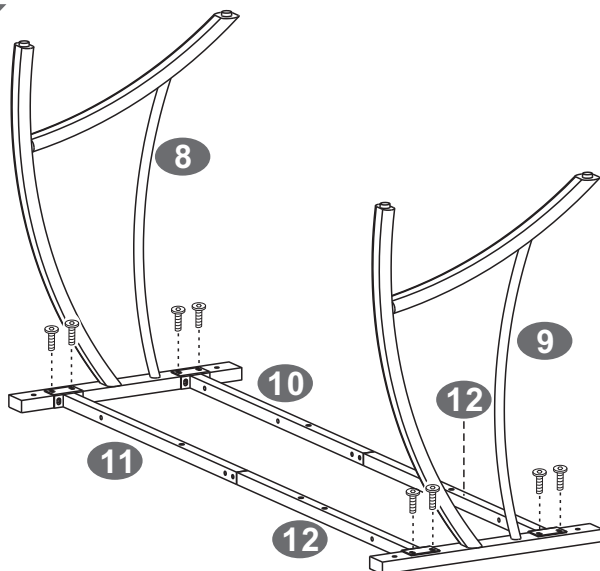

SCREWS

E 6X12 MM X8



A4

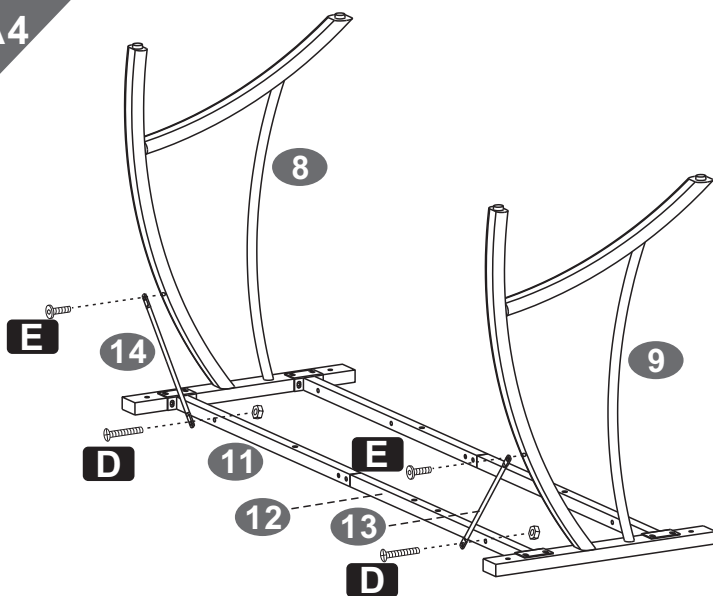

■ SCREWS

D 6X35 MM

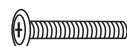
 X2



J M6

 X2



E 6X12 MM

 X2



A5

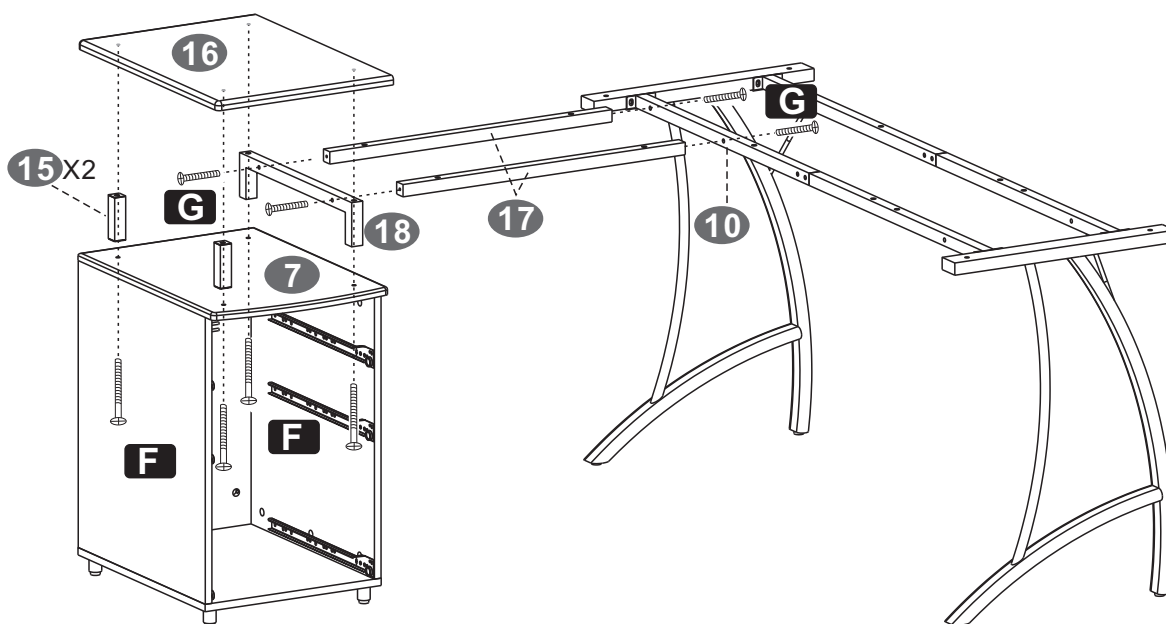

■ SCREWS

G 6X40 MM

 X4

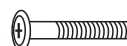

F 6X115 MM

 X4



A6

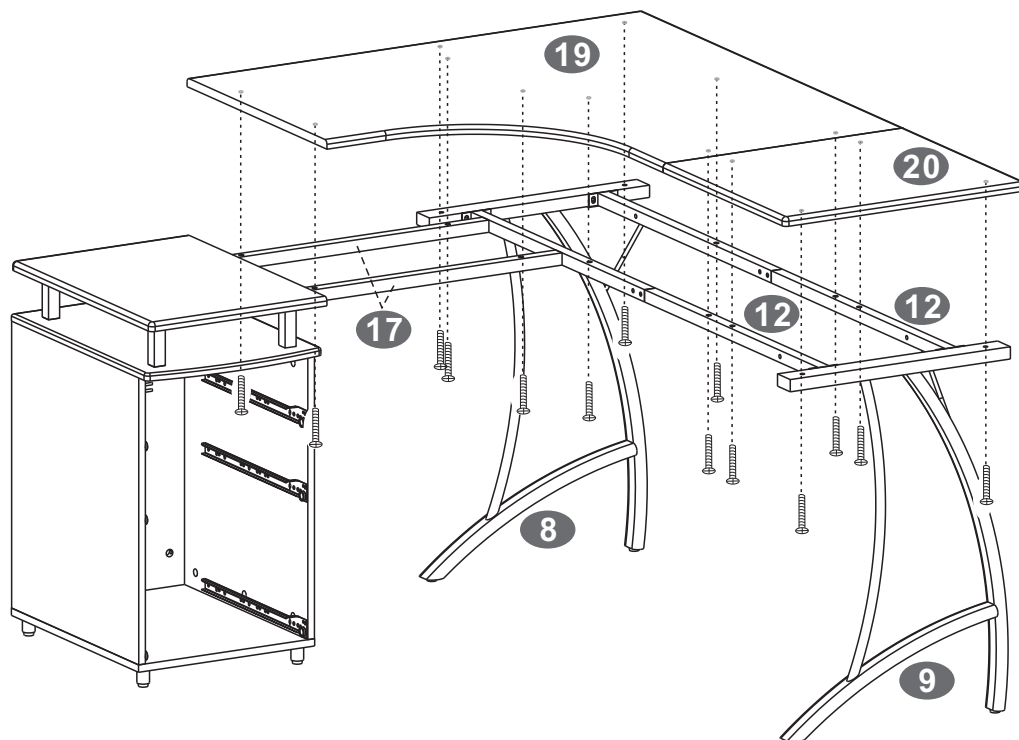

■ SCREWS

D 6X35 MM

 X14



A7

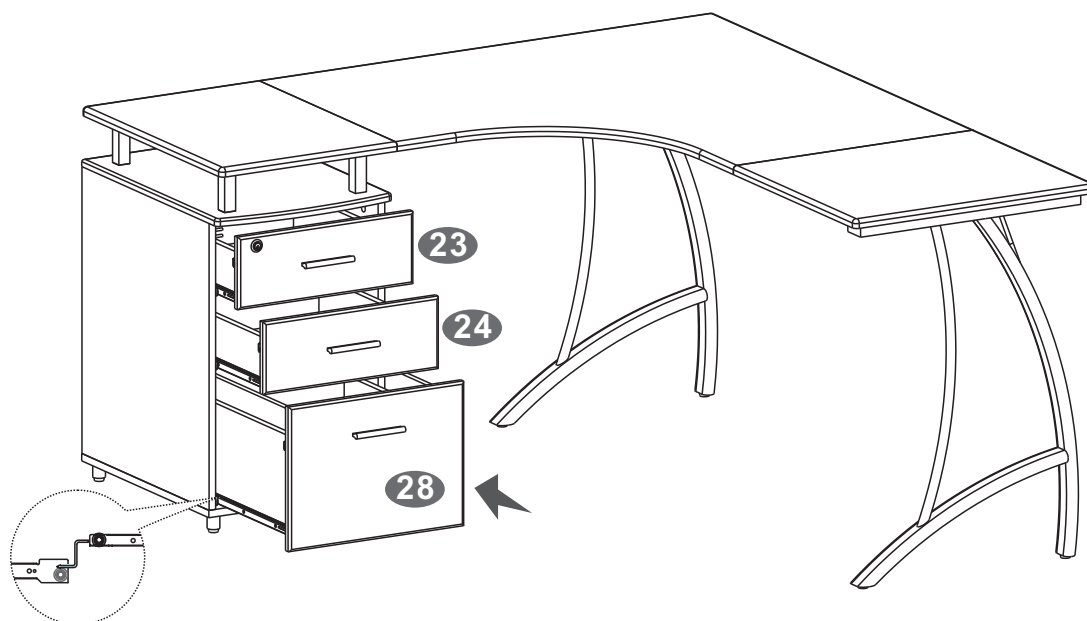

B1

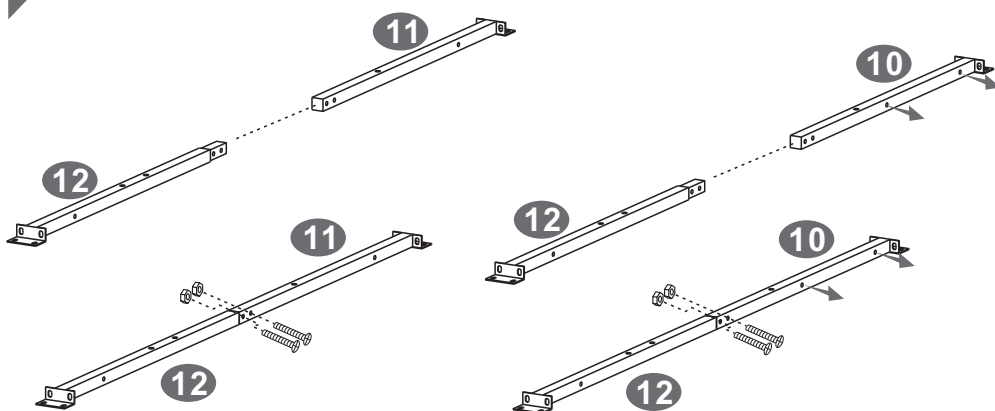

SCREWS

D 6X35 MM

X4



J M6

X4



B2

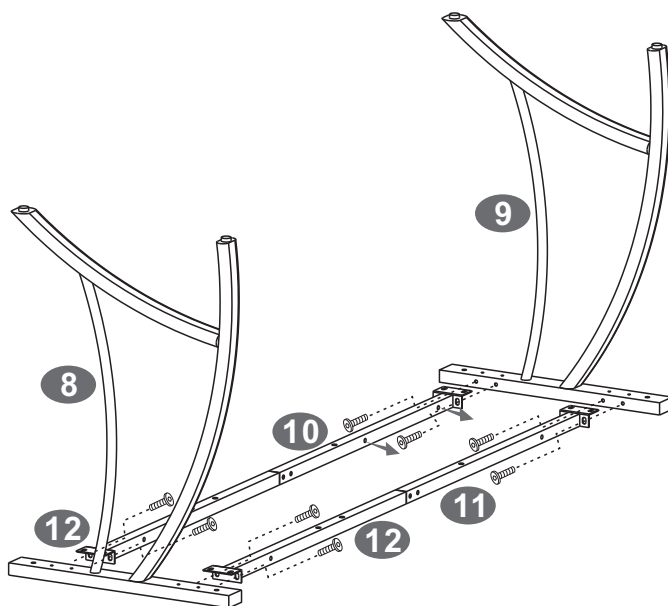

SCREWS

E 6X12 MM

X8



B3

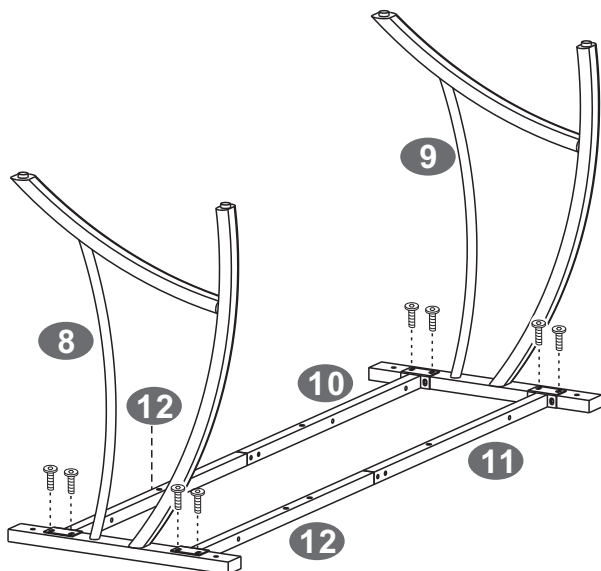

SCREWS



E 6X12 MM

X8



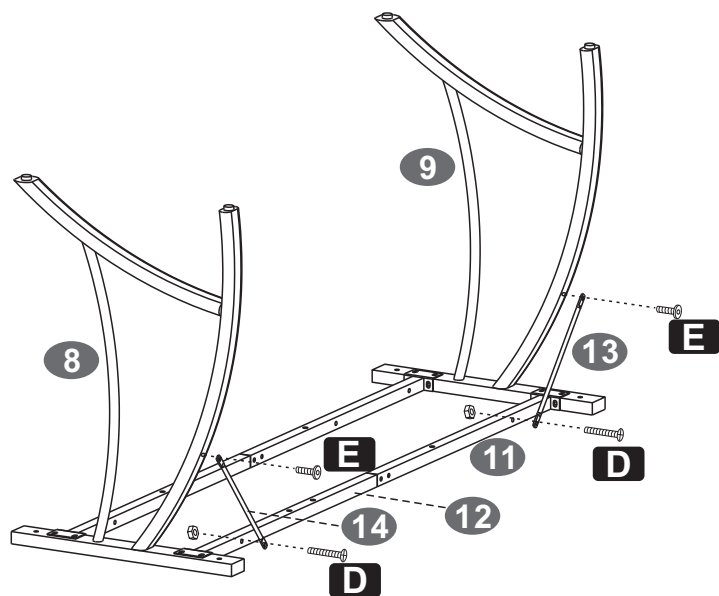

B4

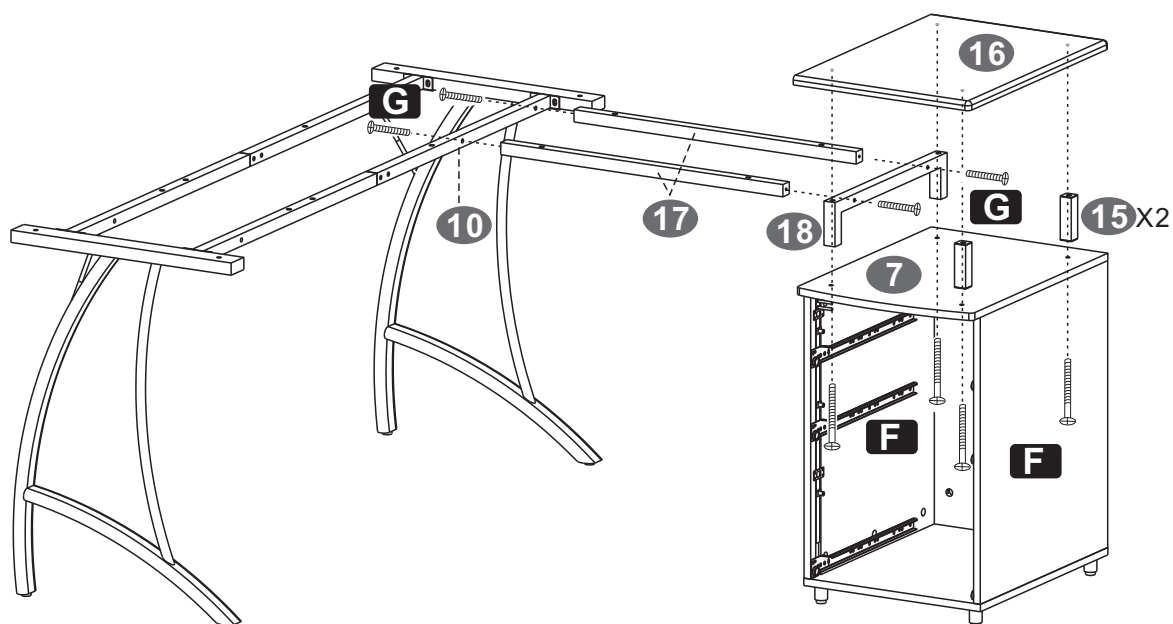

- SCREWS		
D 6X35 MM	X2	
J M6	X2	
E 6X12 MM	X2	

B5



- SCREWS		
G 6X40 MM	X4	
F 6X115 MM	X4	

B6

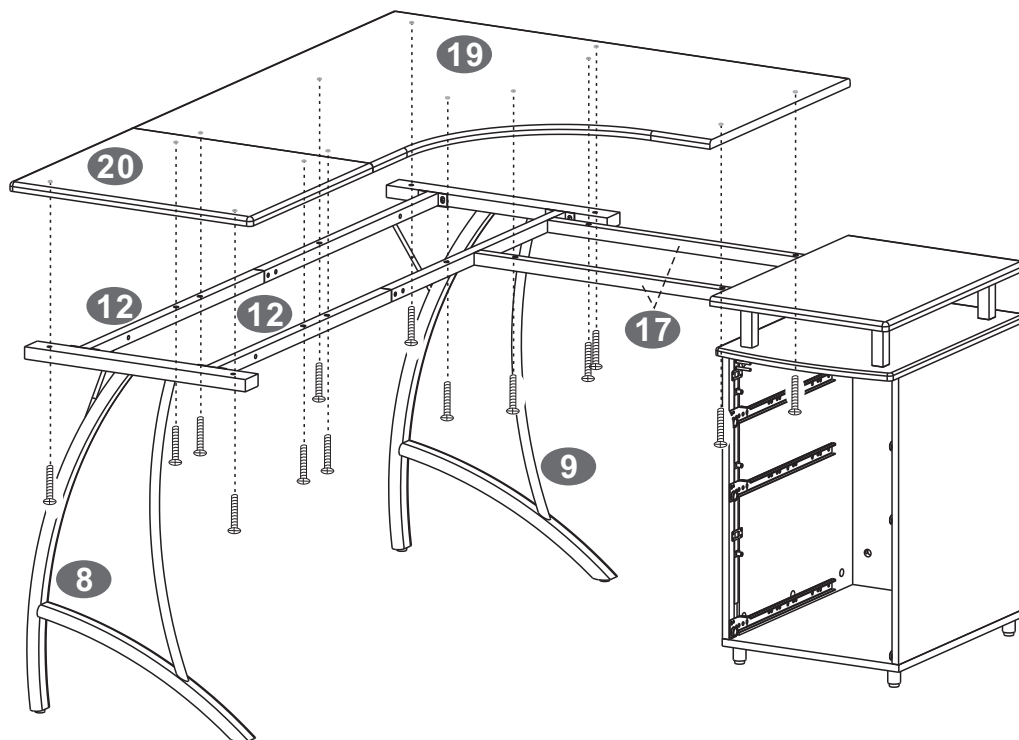

■ SCREWS

D 6X35 MM

 X14



B7

