

20 min	x1	x1	x1

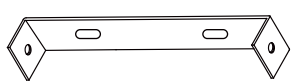

A x 2



B x 1



D x 1



C x 2

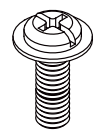

E x 2

OFF

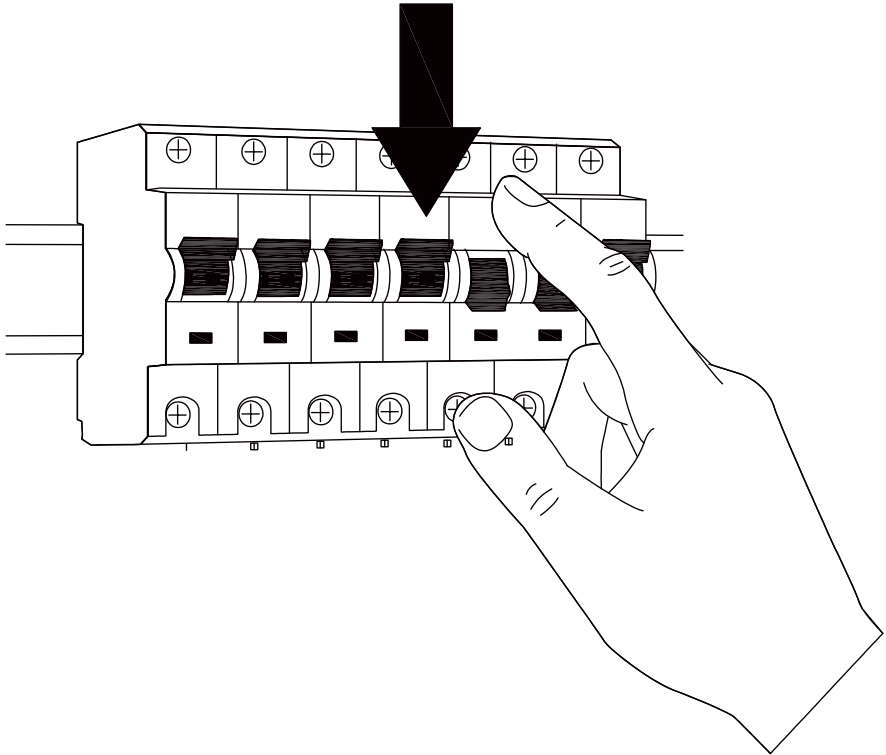

1

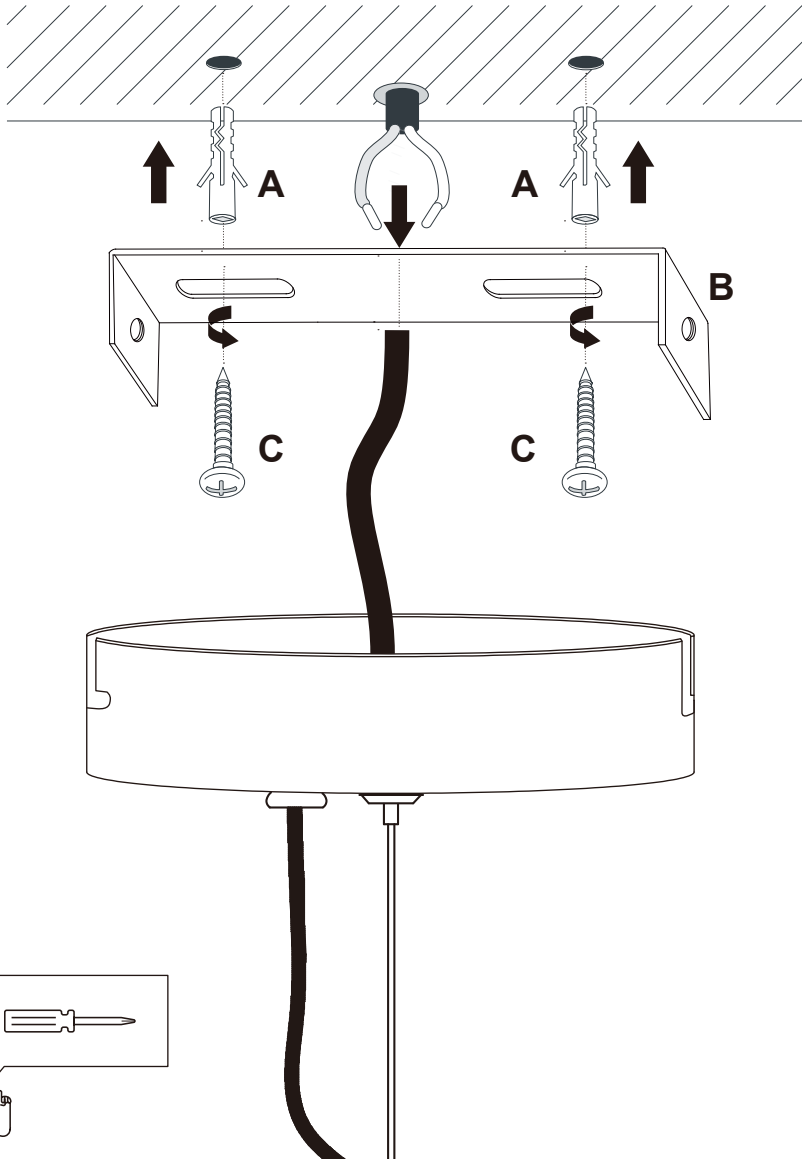

2

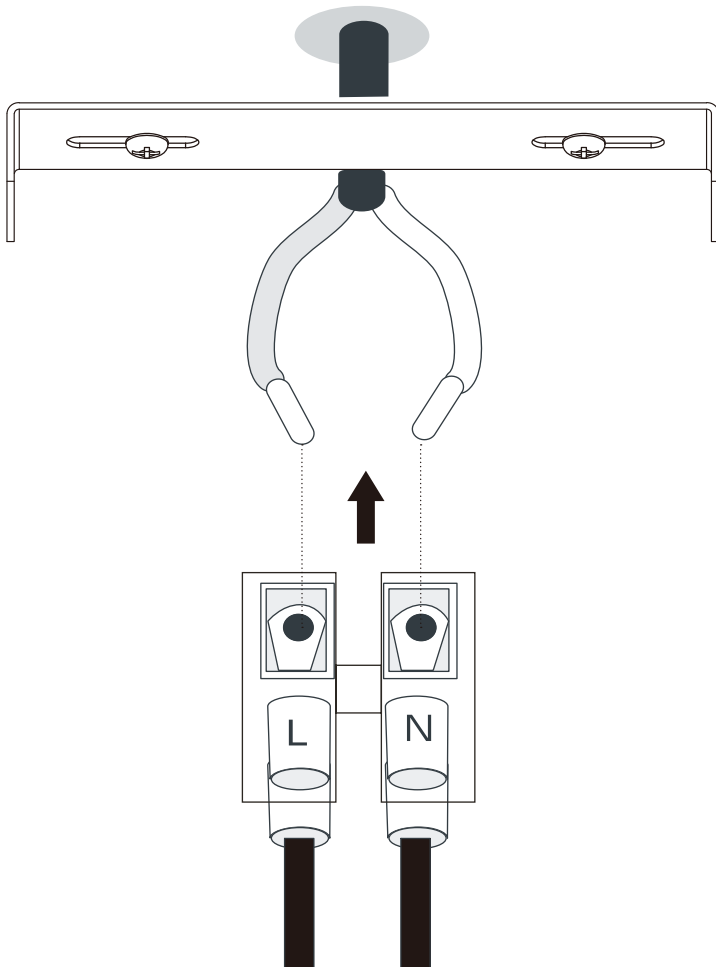

3

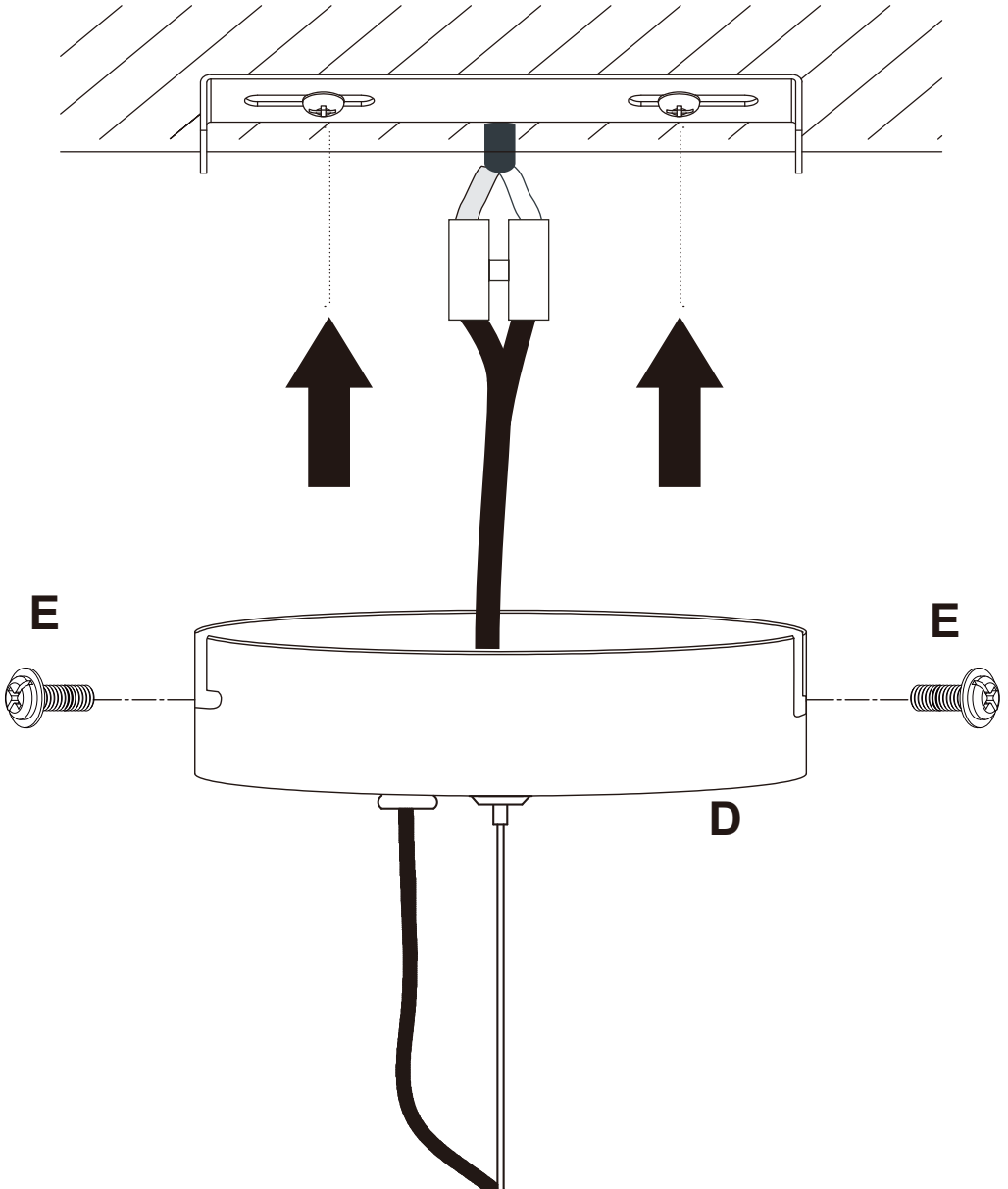

4





THAT'S ALL FOLKS!

Share your style!

#KaveHome

